



**Dongguan Hinen New Energy Technology Co., Ltd**

Add: No.24 Dongkang Road, Dalingshan Town,  
Dongguang City, Guangdong, China  
Email: [service@hinen.com](mailto:service@hinen.com)  
Tel: +86 (769) 89920666 ext 8318  
Website: <https://www.hinen.com>

**Hinen Australia Pty. Ltd.**

Add: Suite 503,Level 5, Tenancy 3,107 Mount Street, North Sydney  
Email: [service@hinen.com.au](mailto:service@hinen.com.au)  
Tel: +61 2 7258 1272  
Website: <https://au.hinen.com>

**Europe HL Hinen B.V.**

Add: John M. Keynesplein 1, 1066EP Amsterdam  
Email: [service@hinen.com](mailto:service@hinen.com)  
Tel: +86 (769) 89920666 ext 8318  
Website: <https://nl.hinen.com>

**Hinen Energy Eastern Europe**

Add: Wąska 95, 05-806 Sokołów Poland  
Email: [biuro@hinen.com](mailto:biuro@hinen.com)  
Tel: +48 606 807 712  
Website: <https://pl.hinen.com>

**Hinen South Africa (Pty) Ltd**

Add:Ground floor, Block B, 100 West Street,  
Sandton.Johannesburg 2196, South Africa  
Email: [SAfrica@hinen.com](mailto:SAfrica@hinen.com)  
Tel: +27 10 449 2306  
Website: <https://za.hinen.com>

**Hinen Technology East Africa LIMITED**

Add: No. 6, Kirichwa Lane Court, next to  
GreenhouseMall, Ngong Road, Nairobi, Kenya  
Email: [EAfrica@hinen.com](mailto:EAfrica@hinen.com)  
Tel: +254789688999  
Website: <https://ke.hinen.com>

**Hinen West Africa LIMITED**

Add: 25A-2 Talabi St, Ogba, Lagos 101233, Lagos, Nigeria  
Email: [WAfrica@hinen.com](mailto:WAfrica@hinen.com)  
Tel: +86 (769) 89920666 ext 8318  
Website: <https://ng.hinen.com>



# 5000Wh BATTERY SYSTEM



## User Manual

## Foreword

- All information in this document is the property of the battery system manufacturer. Any parts of this document shall not be copied or reproduced in any commercial forms. Internal use allowed.
- The manufacturer makes no warranties or guarantees, express or implied, with respect to any device and/or software other than this product that may be described in this document, including, but not limited to, any implied warranties of merchantability, fitness for a particular purpose, accuracy or completeness of responses.
- In no event shall the manufacturer or its distributors or resellers be liable for indirect, incidental or consequential damages arising from non-compliance with the guidelines in this document.
- Specifications in this document are subject to change without notice. Every effort has been made to make this document complete, accurate and up to date. However, the manufacturer may require some improvements under certain circumstances without prior notice. The manufacturer shall not be liable for any damage caused by this document, including but not limited to omissions, typographical errors, arithmetic errors or errors listed in the document.

## Disclaimer

**The manufacturer shall not be liable for direct or indirect battery system damage or property loss caused under the following circumstances.**

- Modify or replace parts without official authorization from the manufacturer.
- Change or clear the serial number by non-manufacturer technical professionals.
- System, assembled with other devices, design and installation fail to meet standards, safety regulations and other relevant requirements.
- Battery system damage caused by failure to comply with the user manual.
- Battery system damage caused by improper use or misuse.
- Battery system damage caused by insufficient ventilation.
- The maintenance procedures do not comply with acceptable standards.
- Battery system damage caused by force majeure, such as earthquake, storm, lightning, overvoltage, fire, etc.
- Battery system damage caused by any external factors.

## Contents

|  |    |
|--|----|
| <b>01 Safety Precautions</b>                           | 1  |
| <b>02 Introduction</b>                                 | 2  |
| 2.1 Applicability                                      | 2  |
| 2.2 Purpose  | 2  |
| 2.3 Symbol Definition                                  | 3  |
| <b>03 Battery System Introduction</b>                  | 4  |
| 3.1 Port Description                                   | 4  |
| 3.2 Dimensions   | 5  |
| <b>04 Storage and Packaging</b>                        | 6  |
| 4.1 Storage Environment                                | 6  |
| 4.2 Packing List                                       | 6  |
| <b>05 Battery System Installation</b>                  | 7  |
| 5.1 Installation Environment                           | 7  |
| 5.2 Space Requirements                                 | 7  |
| 5.2.1 Space Requirement for Floor-mounted Installation | 7  |
| 5.2.2 Space Requirement for Wall-mounted Installation  | 8  |
| 5.3 Battery System Installation                        | 10 |
| 5.3.1 Floor-mounted Installation                       | 10 |
| 5.3.2 Wall-mounted Installation                        | 12 |
| 5.3.3 Cable Connection                                 | 18 |
| <b>06 System Operation</b>                             | 24 |
| 6.1 Checking Before Powering on                        | 24 |
| 6.2 Powering on the Battery System                     | 24 |
| 6.3 Viewing and Configuring Battery Parameters         | 25 |
| 6.4 Indicator Status                                   | 29 |
| 6.4.1 Normal Status                                    | 30 |
| 6.4.2 Alert State                                      | 31 |
| 6.4.3 Fault State                                      | 32 |
| 6.5 Powering off the Battery System                    | 33 |
| <b>07 Maintenance</b>                                  | 34 |
| <b>08 Technical Specifications</b>                     | 35 |
| 8.1 Standard Battery System                            | 35 |
| 8.2 Battery System with Heating Function               | 37 |

## 01 Safety precaution

### **Danger!**

- Please keep power off before any operations to avoid danger. Strictly follow all safety precautions outlined in this manual and safety labels on the equipment during operation.
- This manual applies to trained and knowledgeable technical professionals. The technical personnel has to be familiar with the product, local standards, and electric systems.
- Do not use the battery if it is defective, broken, or damaged.
- Do not disassemble, modify, or replace any parts of the battery without official authorization from the manufacturer.
- Battery damage may cause electrolyte leak. If leak happens, avoid contacting with the leaking liquid or gas, but contact the after-sales service as soon as possible.

### **Warning!**

#### **Anyone contacting the leaked substance accidentally has to do as follows:**

- Breath in the leaked substance: Evacuate from the polluted area, and seek immediate medical assistance.
- Eye contact: Rinse your eyes for at least 15 minutes with clean water and seek immediate medical assistance.
- Skin contact: Thoroughly wash the touch area with soap and clean water, and seek immediate medical assistance.
- Ingestion: Induce vomiting, and seek immediate medical assistance.
- Do not move the battery system if it is connected with external battery modules. Contact after-sales service if the battery shall be replaced or added.

### **Caution!**

#### **Transportation:**

- Protect the battery system from damage during transportation and storage.
- Be careful and consider the weight when lifting the battery.
- Do not hit, pull, drag, or step on the equipment or put irrelevant matter into any parts of the battery system .
- To protect the battery pack and its components from damage during transportation, please ensure that the transportation personnel are professionally trained. All operations during the transportation have to be recorded.
- The equipment shall be kept in balance, thus avoiding falling down, product damage and personnel injury.
- In the event of a fire, please make sure that the carbon dioxide extinguisher or Novac1230 or FM-200 is nearby.
- The fire cannot be put out by water or ABC dry powder extinguisher. Firefighters are required to wear full protective clothing and self-contained breathing apparatus.
- The battery may explode when the ambient temperature exceeds 150°C.
- The battery equipment is heavy. Please equip the corresponding personnel according to its weight, so that the equipment does not exceed the weight range of the human body can carry, and cause personnel injury.
- Place the cables at least 30mm away from the heating components or heat sources, otherwise the insulation layer of the cables may be aging or broken due to high temperature.
- Tie the cables of the same type together, and place cables of different types at least 30mm apart. Do not place the cables entangled or crossed.

## 02 Introduction

### 2.1 Applicability

The manual applies to the following product models:

- B5000
- B5000-W

#### **System Lock:**

If the battery exceeds the specified limits (voltage, current, or temperature) during operation, the system will be locked and cannot recover automatically. Please contact the manufacturer for a reset.

### 2.1 Purpose

This user manual provides an introduction to the 5kWh storage battery system (hereinafter referred to as the "battery system"), including product details, applications, installation, commissioning, maintenance, technical parameters, and more. The battery system is compatible with the H6000 inverter, and up to 10 battery systems can be connected in parallel.

## 2.3 Symbol Definition

| Symbol  | Description   |
|---|---|
|    | Potential risks exist. Wear proper PPE before any operations.   |
|    | High voltage hazard.<br>Power off the equipment first before any operations.  |
|    | Operate the equipment properly to avoid explosion danger.   |
|    | The equipment contains corrosive electrolytes. In case of a leak in the equipment, avoid contacting the leaked liquid or gas. |
|    | Read through the user manual before any operations.   |
|    | Pay attention to personal protection during installation and maintenance.   |
|    | Install the equipment away from fire sources.   |
|    | Keep the equipment away from children.  |
|    | Do not dispose of the equipment with household garbage at its end of life.  |
|   | Put the battery in the right place and recycle it in compliance with local environmental regulations.                         |
|  | CE mark.  |
|  | RCM mark.   |
|  | Grounding. To indicate PE cable connection position.  |

## 03 Battery System Introduction

### 3.1 Part introduction

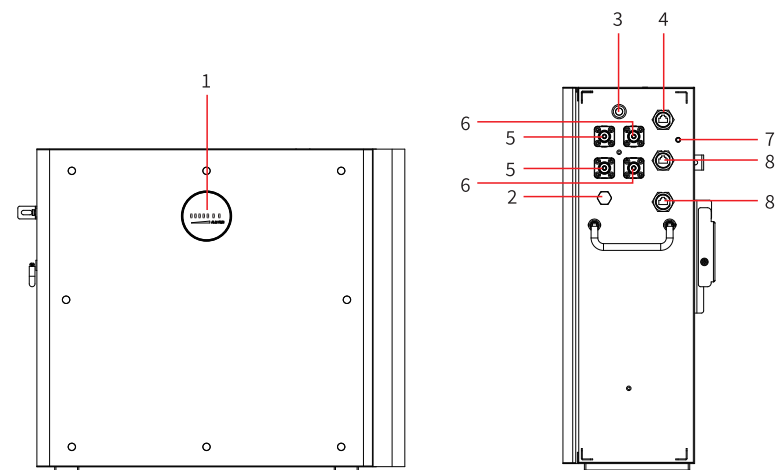

### Port definition

| No. | Part               | Description   |
|-----|--------------------|---|
| 1   | SOC indicator      | Capacity indication, working together with the switch button to show battery status |
| 2   | Ventilation valve  | Prevent too high air pressure inside the case                                       |
| 3   | Switch button      | Turn on/off the battery system  |
| 4   | COM port 1         | INV communication transmission  |
| 5   | BAT+               | Battery positive polarity power transmission  |
| 6   | BAT-               | Battery negative polarity power transmission  |
| 7   | Grounding terminal | Grounding protection  |
| 8   | COM port 2         | Capacity expansion communication transmission                                       |

### 3.2 Dimensions

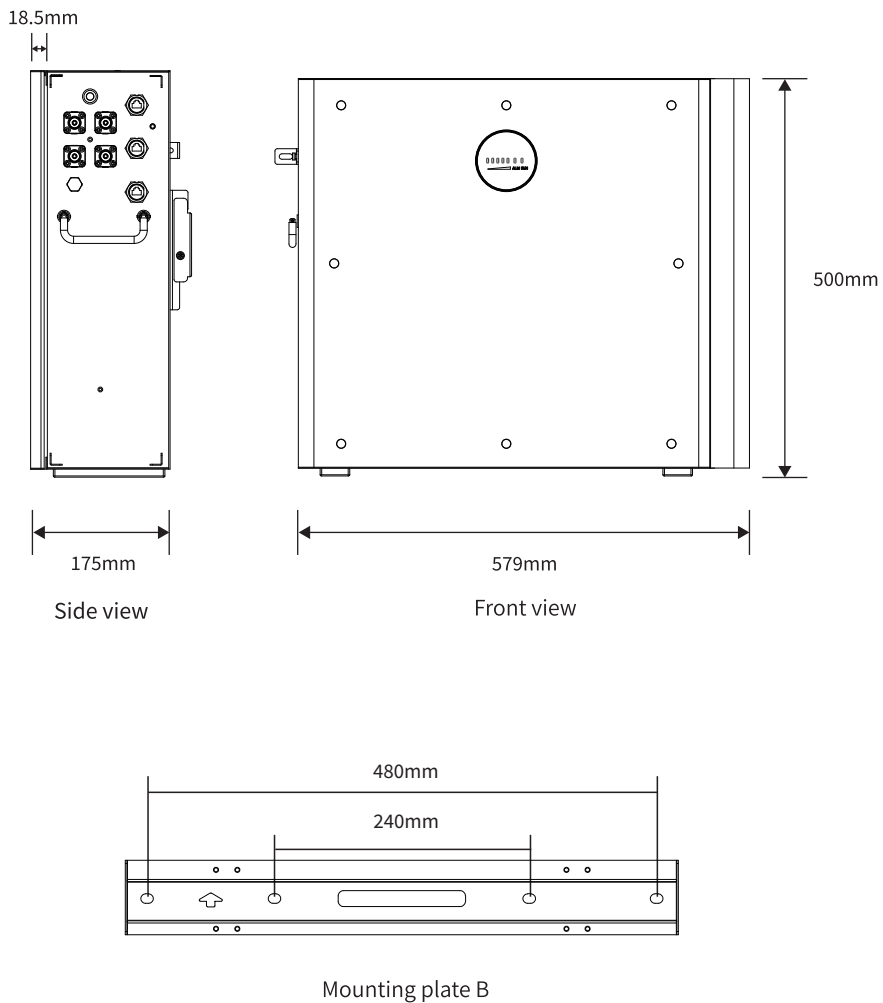

**Note:** The material of the external enclosure is SGCC (Steel Galvanized Cold Command). The face cover material is 1.0 mm thick and the chassis material is 1.5 mm thick.

## 04 Storage and package











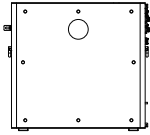

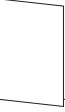

### 4.1 Storage environment

If the equipment is not to be installed or used immediately, please ensure that the storage environment meets the following requirements:

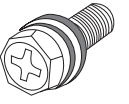
- Pack the equipment with a packing box and put some desiccant in the box before sealing.
- Put the equipment back to the packing box if it is not to be installed in 3 days after unpacking.
- Storage SOC: 25%~50%SOC. Charge and discharge the battery every 3 months.
- Recommended storage temperature: -20°C~40°C (less than one month) or 0°C~35°C (less than one year).
- Recommended storage humidity: 0%~95%RH (no condensation). Do not install the battery if any moist or condensation is found.
- Place the equipment in a cool place where away from direct sunlight.
- Keep the equipment away from inflammable, explosive, and corrosive matters.
- Keep the equipment away from rain.
- Place the equipment away from corrosive and organic materials and gases.
- Keep the equipment at least two meters away from heat sources (such as a radiator).
- Avoid exposure to intensive infrared radiation.

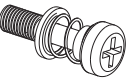
### 4.2 Packing list

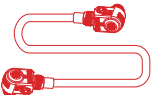
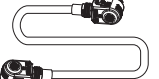
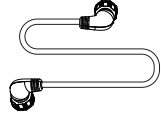
- Check outer packing for damage and model before unpacking it. If you find any damage or the model is not what you requested, do not unpack the product and contact the after-sales service as soon as possible.
- Check whether the deliverables are intact and complete first after unpacking the battery. If anything wrong, contact the after-sales service as soon as possible.

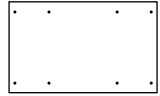
|  |   |  |  |  |
|--|---|--|--|--|
| <br>Battery system x1           | <br>Mounting plate A x4  | <br>Mounting plate B x2     | <br>Mounting plate C x4         | <br>Side cover x1             |
| <br>Anti-dumping bracket x2   | <br>User manual x1      | <br>Grounding terminal x1 | <br>M5 cross hexagon screw x13 | <br>Expansion bolt x10       |
| <br>M4 cross hexagon screw x2 | <br>M4 spring screw x2 | <br>Silicone plug x2      | <br>Red parallel cable x1     | <br>Black parallel cable x1 |
| <br>Parallel Signal cable x1  | <br>Screw nut x12      | <br>Positioning card x1   |  |  |

## 05 Battery System Installation

### 5.1 Installation environment

- The 5000Wh battery system protection level meets both indoor and outdoor installations. The installation location must ensure that the use of the batteries is unaffected by structures, fixtures and fittings in the building.
- The 5000Wh battery system is naturally ventilated. The installation location should be clean, dry and well ventilated. To ensure air circulation, install outside one meter of any vertical plane of a window or building vent that ventilates a habitable room.
- Entrance doors and panels to the room should open towards the exit and allow unobstructed access to the battery for installation and maintenance.
- Install the battery system on the ground with sufficient bearing capacity and flatness. If not, increase the bearing capacity and flatness of the ground by laying the foundation, adding bearing plates and so on.
- The optimal temperature for the battery is 20~40°C.
- Avoid exposing the equipment to direct sunlight or rain. A sheltered location is recommended, and an awning can be installed if necessary.
- Keep the equipment at least two meters away from heat sources, such as direct sunlight, a fireplace, a thermally insulated wall exposed to sunlight, hot water, or a heater.
- Install the equipment away from cold source.
- Do not install the equipment in the place where the temperature changes extremely.
- Install the equipment away from strong interferences to ensure its regular work.
- Keep children away from the equipment.
- Do not install the equipment in places prone to accumulating water.
- Do not put inflammable or explosive matters near the equipment.

**WARNING:** The battery cover must not be removed without official authorization. For any maintenance or repairs at the cell component level, the battery module must be returned to the manufacturer or a qualified service agent to prevent unsafe situations.

## 5.2 Space requirements

### 5.2.1 Space Requirement for Floor-mounted Installation

**Note** Distances at both sides are recommended distances. Shorten the distance as much as possible in a proper range.

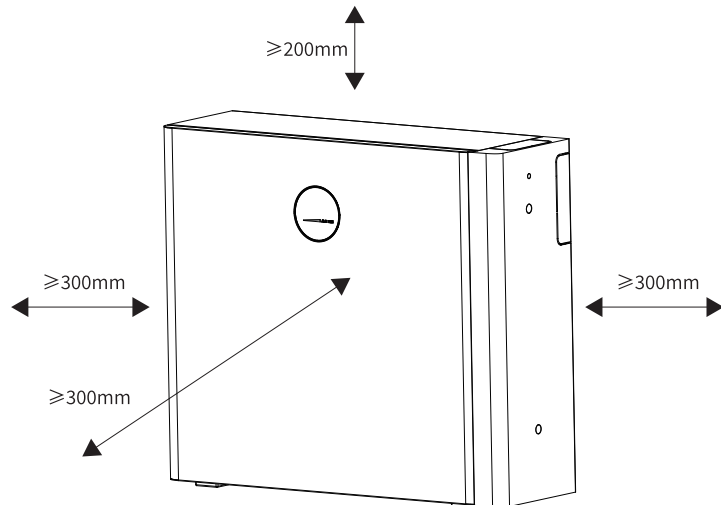

### 5.2.2 Space Requirement for Wall-mounted Installation

**Note** Distances at both sides are recommended distances. Shorten the distance as much as possible in a proper range.

#### Installed in single row

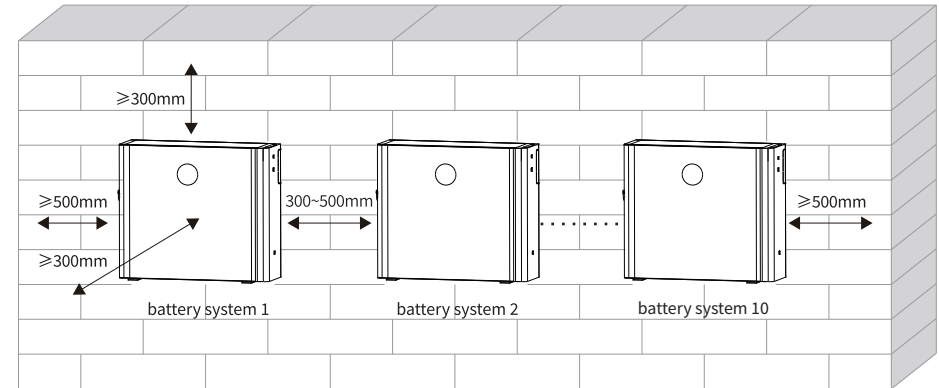

#### Installed in double rows

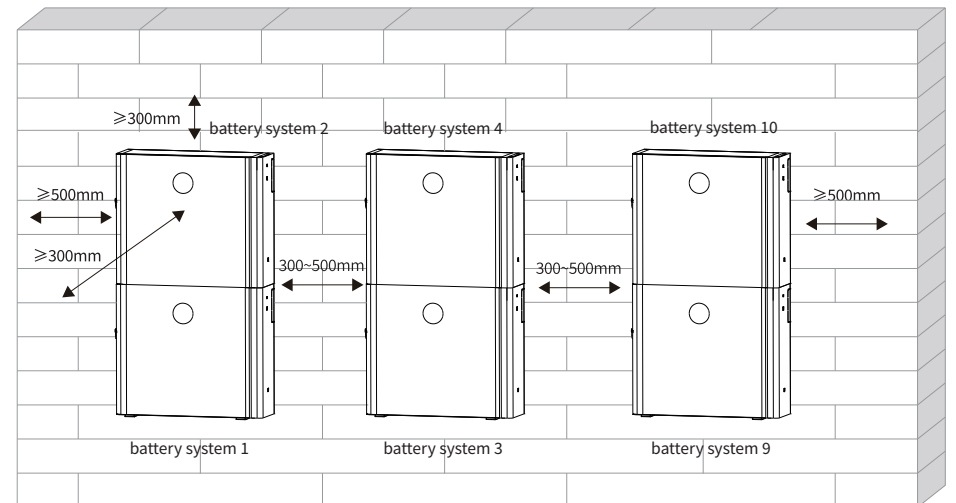

## Installed in three rows

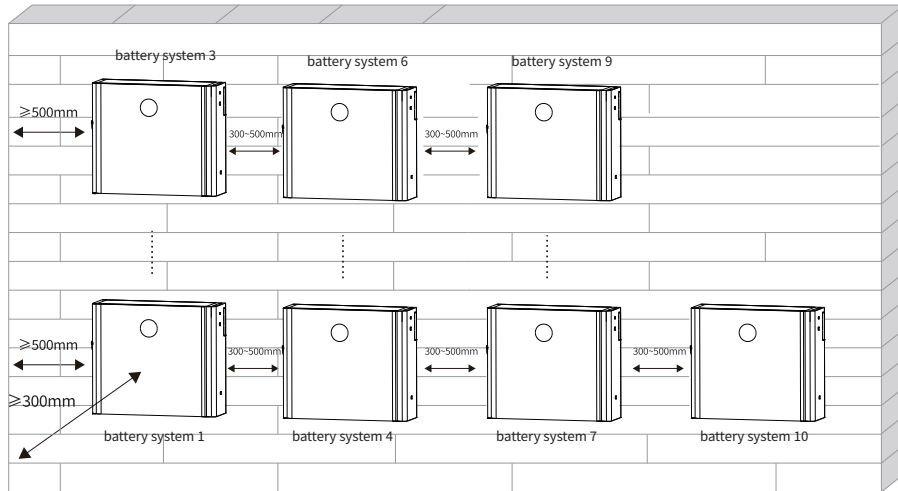

## 5.3 Battery System Installation

**Note** Battery systems in parallel shall be with close manufacturing dates and same range of OCV difference.

### 5.3.1 Floor-mounted Installation

**Note** Ensure the ground is flat and not tilted, and anti-dumping brackets are installed at both sides.

- Screw the anti-dumping bracket on the battery.
- Align the battery and the wall, then put the anti-dumping bracket close to the wall. Mark the drilling position and remove the battery.
- Drill a hole on the wall with a driller, hole diameter 8mm, depth 80mm.
- Fix the expansion bolts, tightening torque: 10N·m.
- When wiring is complete, snap on the side cover, aligning the corners of the cover with the corner tabs on the side of the battery. (See the Wiring section for information on how to wire the battery).
- Secure the side cover with M4 spring screws. (The side cover serves to protect the wiring.)

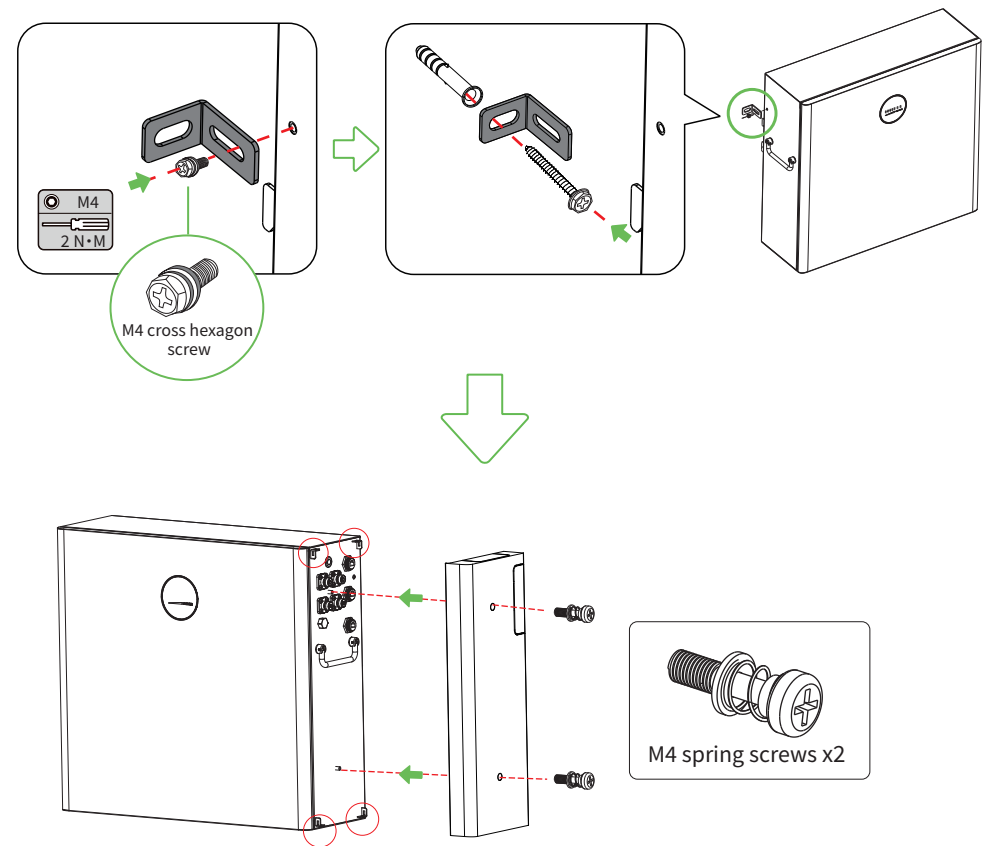

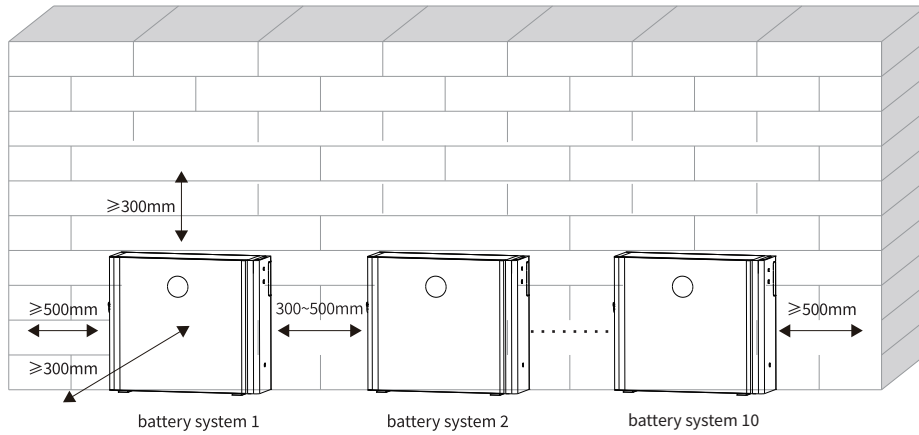

Note: Floor-mounted installation allows batteries to be installed in a single row. Secure the anti-tip brackets on the wall and battery to ensure safety. Batteries cannot be directly stacked on top of the bottom battery if installed on the ground, unless wall-mounted installation is also used.

### 5.3.2 Wall-mounted Installation

#### Single installation

**Note** Wall mounting requires two people to install.

1. Use the screw nuts to secure the 2 mounting plates B and 2 mounting plates C together to form a combination backplate.
2. Position the positioning card as a template so that the positioning card is parallel to the ground and against the wall. Make sure it is securely placed, use a marker to mark where to drill the holes, and remove the positioning card.
3. Drill holes in the wall with an impact drill (hole diameter: 8mm, depth: 80mm).
4. Fasten the Expansion bolts with a torque of 10N·m.

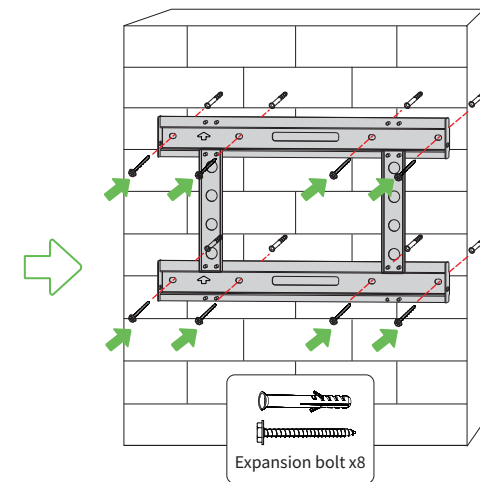
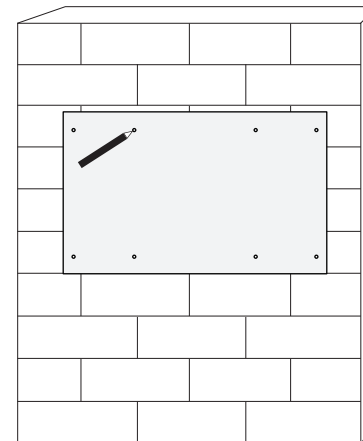
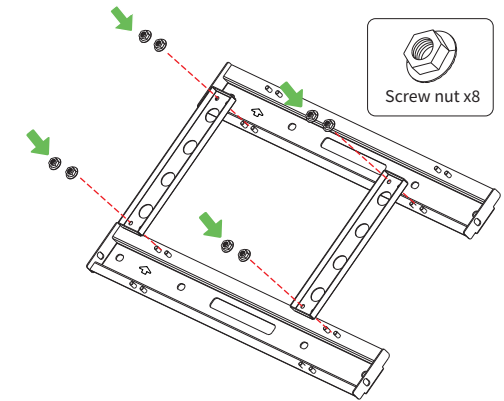
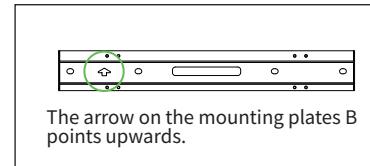

5. Install mounting plates A on the chassis, making sure it is installed securely.
6. Two people lift the handles on both sides respectively, lift the battery parallel to the ground, hang the installed mounting plates A on the mounting plates B of the combination backplate, and then fix it with screws.

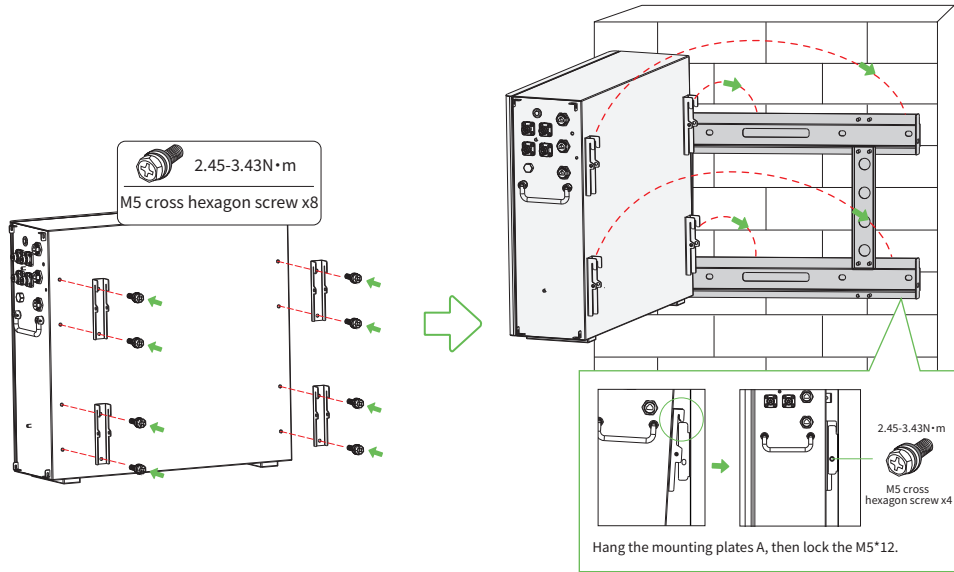

7. When wiring is complete, snap on the side cover, aligning the corners of the cover with the corner tabs on the side of the battery. (See the Wiring section for information on how to wire the battery).
8. Secure the side cover with M4 spring screws. (The side cover serves to protect the wiring.)

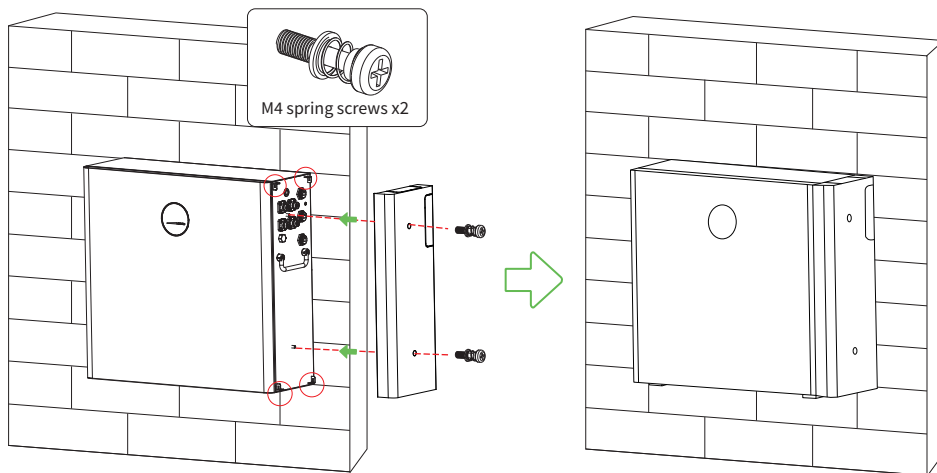

**Stack installation** **Note** Wall mounting requires two people to install.

1. Use the screw nuts to form 4 mounting plates B and 4 mounting plates C into 2 combination backplates each. (If you stack three batteries, you will need to assemble 3 combination backplates).
2. Use 2 mounting plates C to connect and fix the 2 combination backplates together.
3. Position the positioning card as a template so that the positioning card is parallel to the ground and against to the wall. Make sure it is securely placed, use a marker to mark where to drill the holes, and remove the positioning card.
4. Drill holes in the wall with an impact drill (hole diameter: 8mm, depth: 80mm).
5. Fasten the Expansion bolts with a torque of 10N·m.

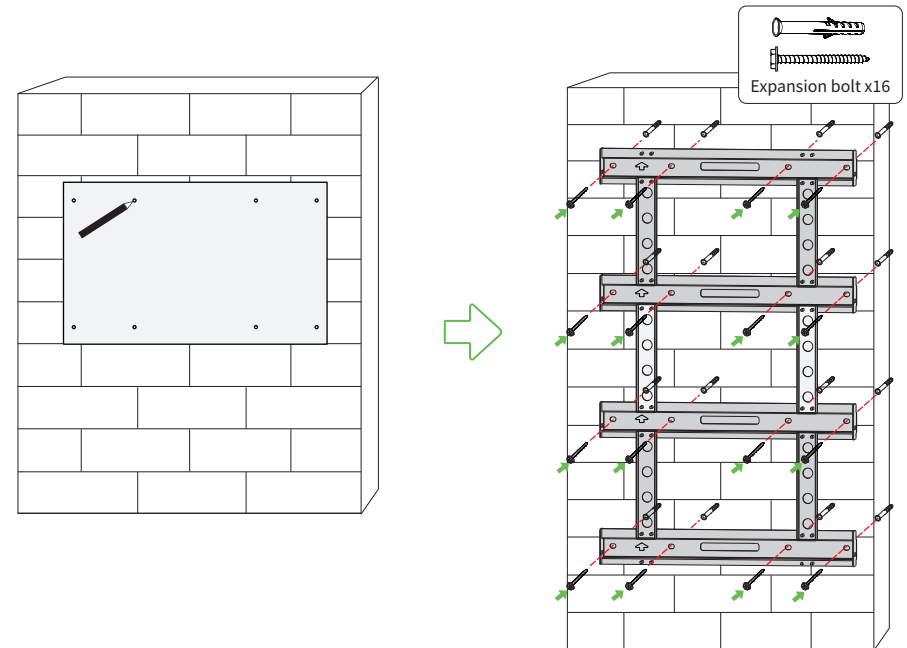
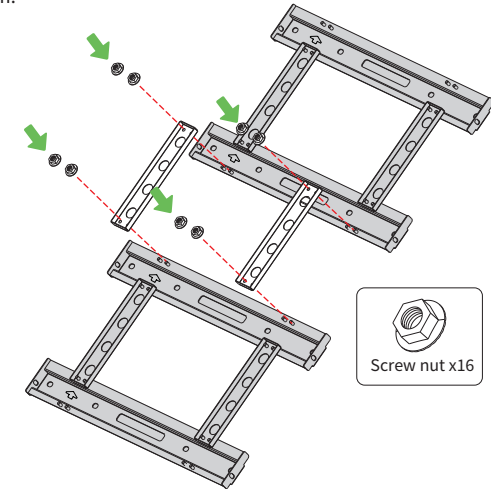
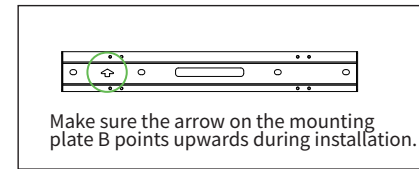

6. Attach the mounting plates A to each of the 2 chassis, making sure it is securely mounted.
7. Two people lift the first battery parallel to the ground by lifting the handles on both sides, and then hang the installed wall plate A into the wall plate B of the combination backplates below, and then fix it with screws.

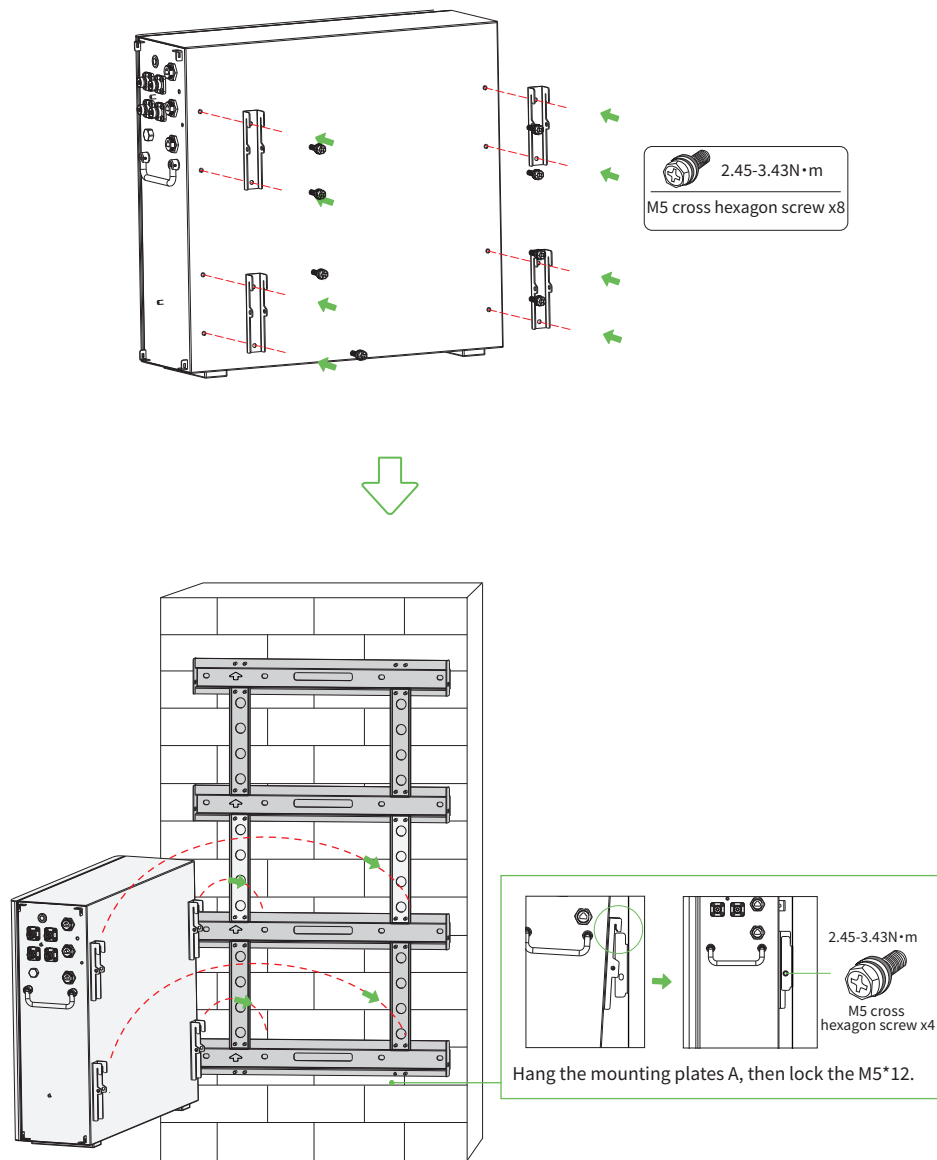

8. Remove the foot pad of the second battery.
9. After the foot pad is removed, two people lift the handles on both sides of the second battery and lift the battery parallel to the ground. Hang the mounting plate A into the mounting plate B of the combination backplate above, and then fix it with screws.

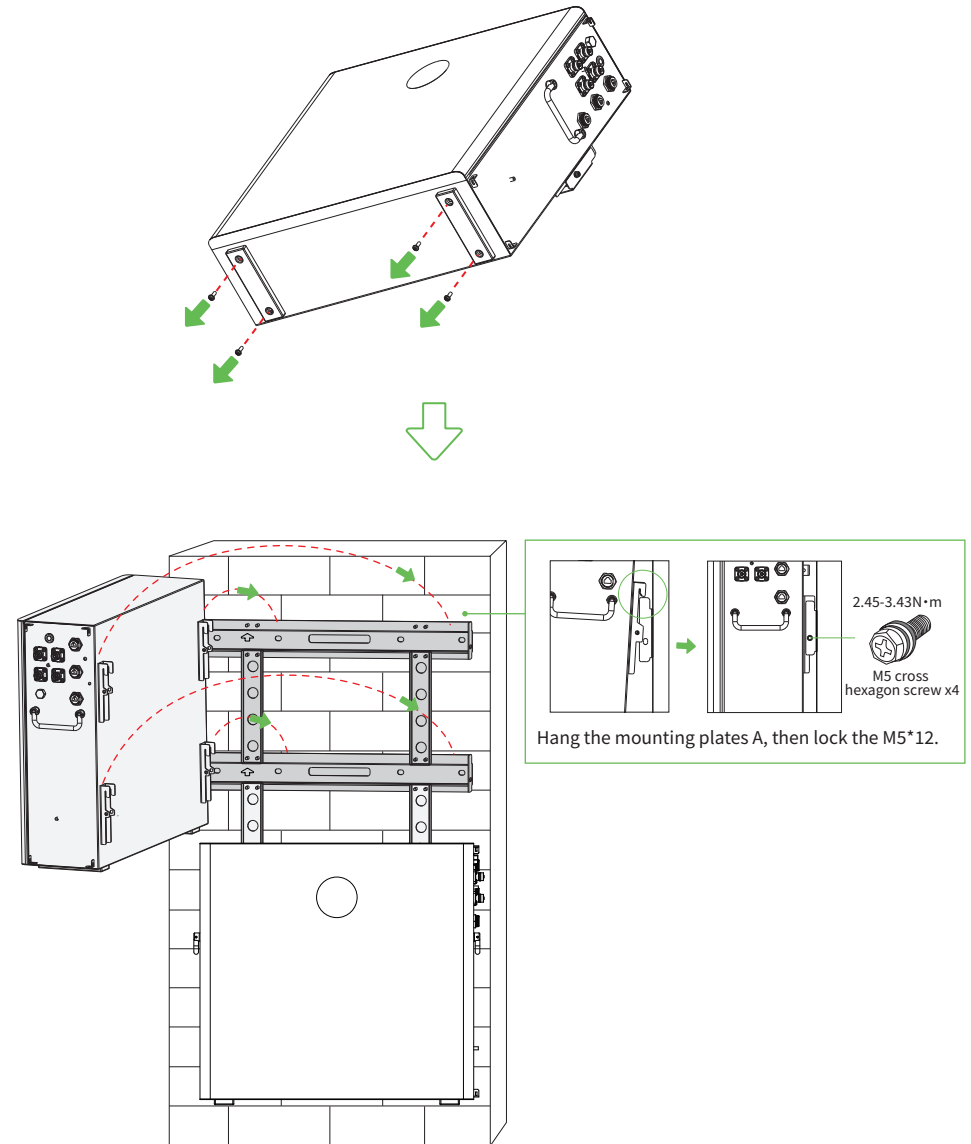

10. When wiring is complete, snap on the side cover, aligning the corners of the cover with the corner tabs on the side of the battery. (See the Wiring section for information on how to wire the battery).

11. Secure the side cover with M4 spring screws. (The side cover serves to protect the wiring.)

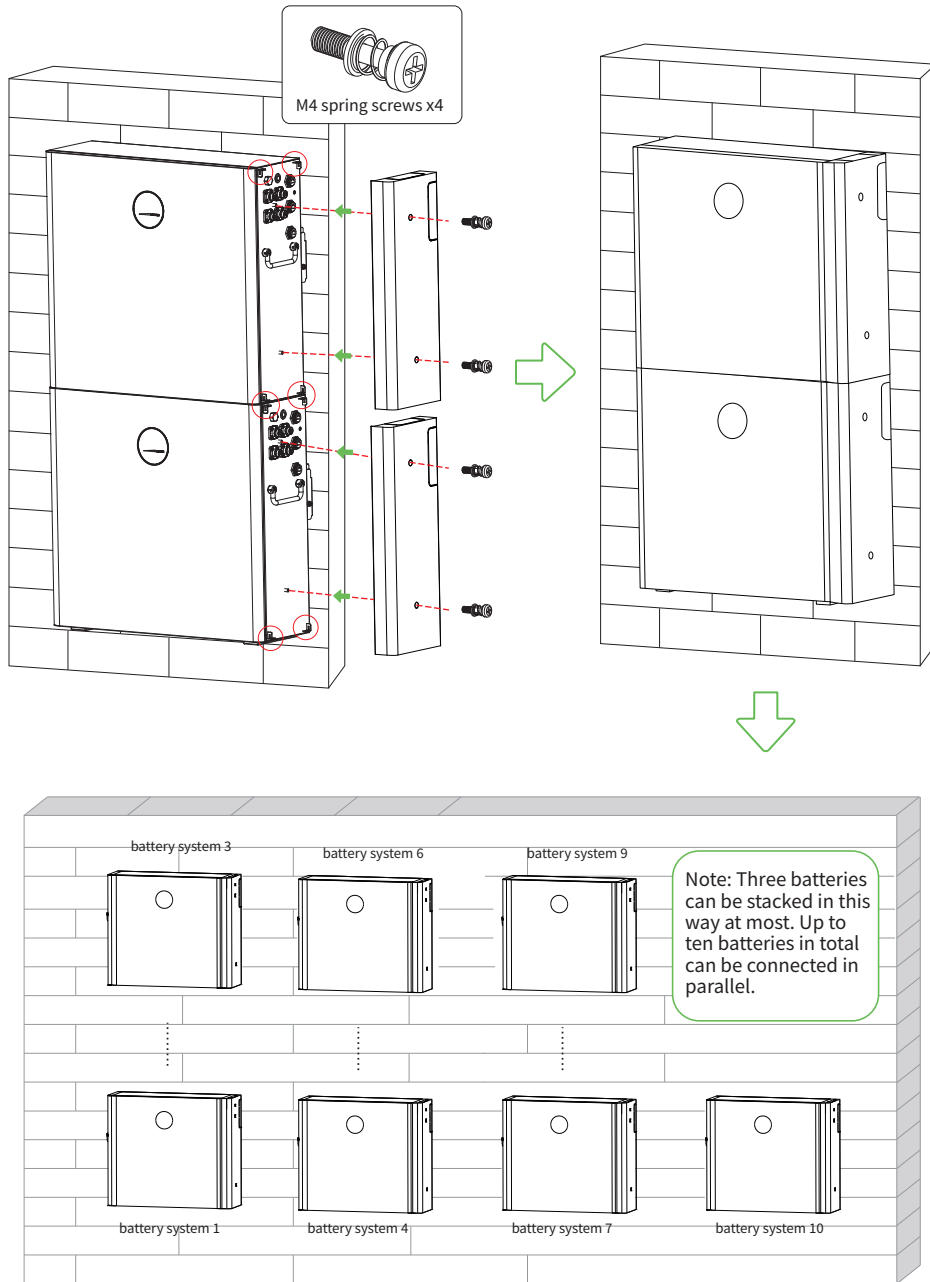

### 5.3.3 Cable connection

Cable connection overview

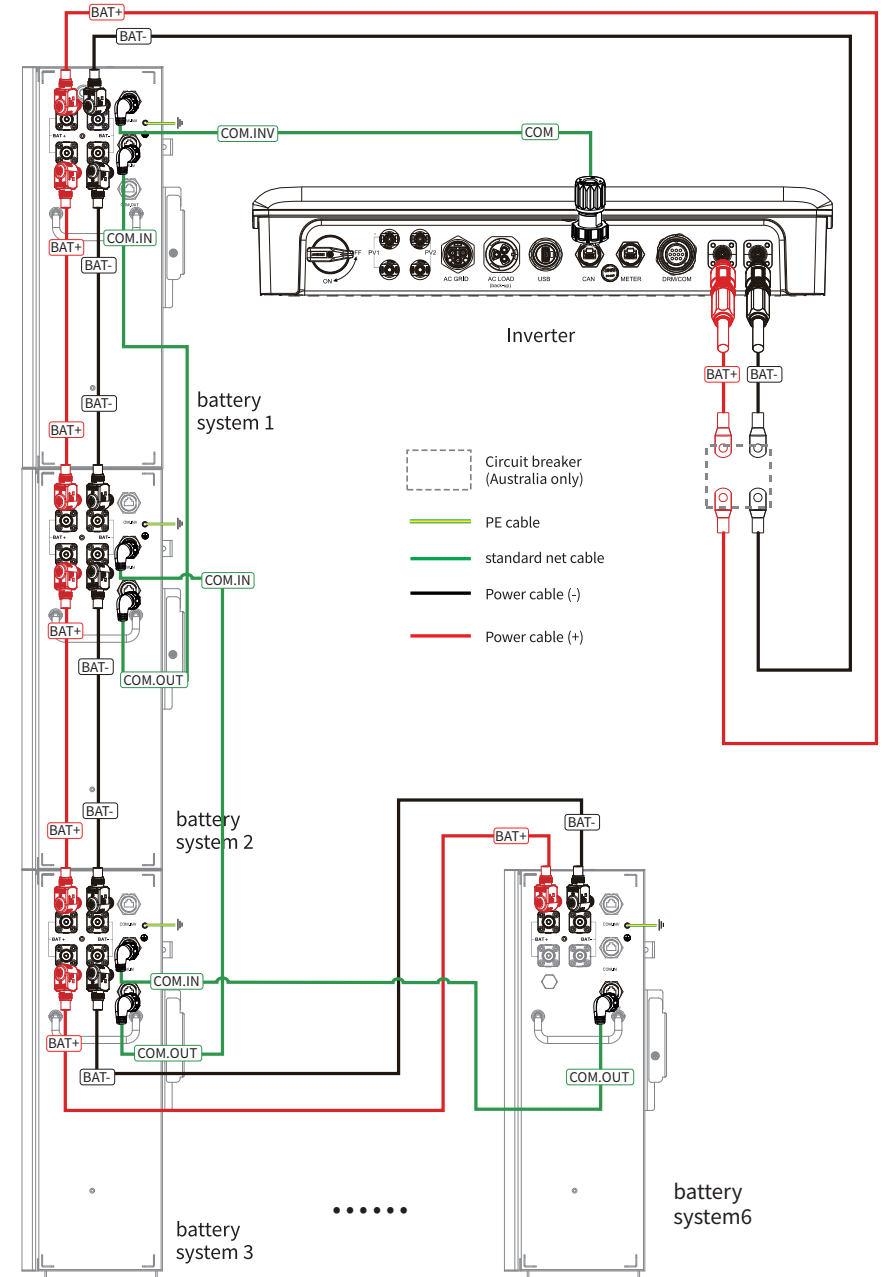

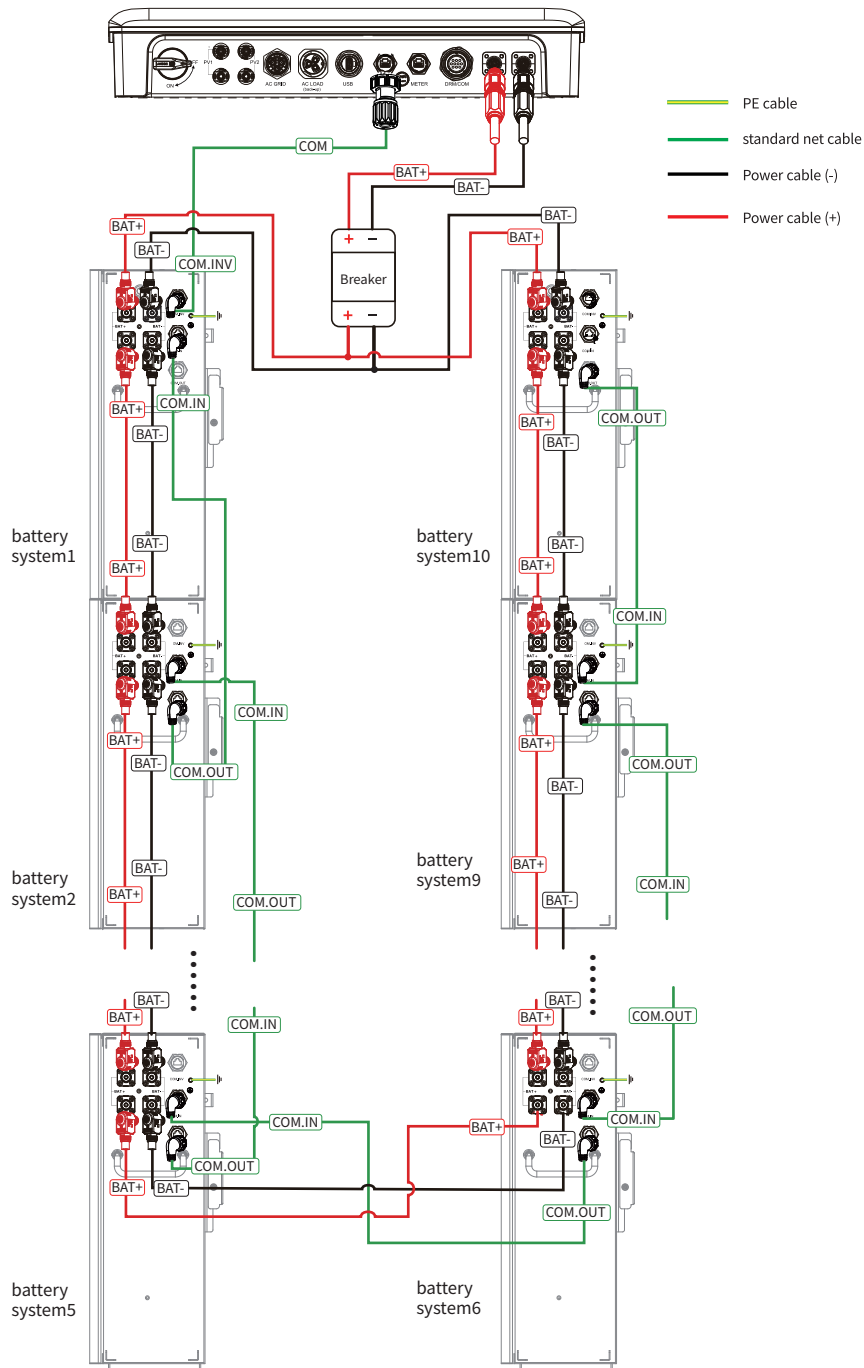

## PE cable connection

### Note

- Connect the PE cable first before installing the equipment. Disconnect the PE cable before dismantling the equipment.
- The drawing force of the cables after crimping is at least 400N.
- Connect any one of the two PE cables to the ground. Reserve the other cable.
- The cross-sectional area of the PE cable conductor:  $5\text{mm}^2$ . The cable should meet standards for outdoor use.
- Applicable screw: M5X12.

### 1. Crimp the PE cable.

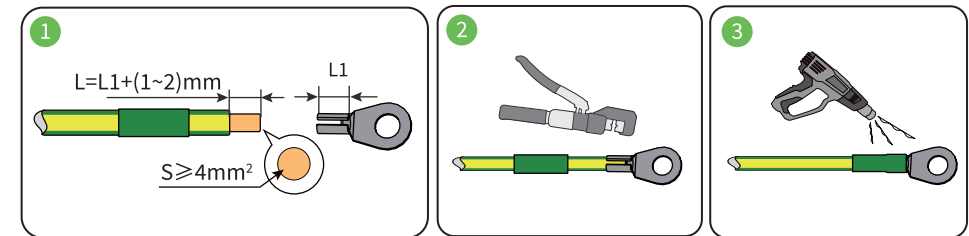

### 2. Connect the PE cable to the battery system .

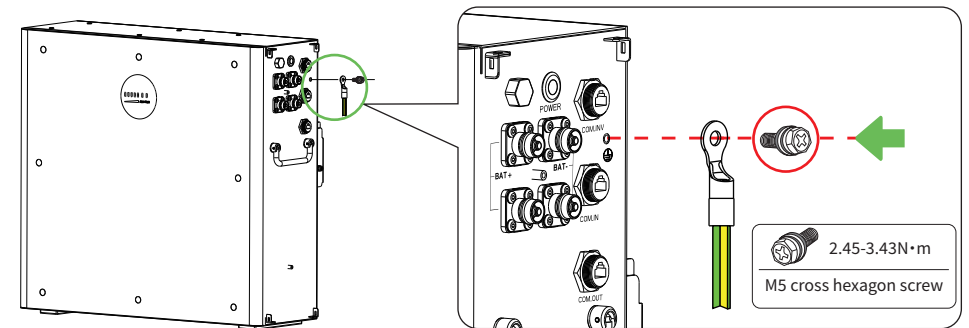

## Power cable connection

### Note

• Connect the red power cable to the red wire harness, and the black power cable to the black wire harness. The cross-sectional area of the crimping part is 25mm<sup>2</sup>. The cable should meet standards for outdoor use.

- Withstand voltage: DC1500V, temperature: -40°C~200°C.
- Stripped conductor length: 18±1mm.
- Secure the back case and check whether there is any gap.
- Recommended tool: manual hydraulic press plier (mould:25mm<sup>2</sup>)
- Drawing force after crimping≥1200N.
- If a single battery is applied, you are suggested to connect any one of the two power ports and cover the other port using the protective cover.
- Connect power cables between multi batteries in parallel, which means connect positive pole of one battery to the positive pole of the next battery, and negative pole to negative pole. Cover and protect the reserved power port of the last battery.
- The power cable between the batteries should be as short as it can be and meet installation requirements.

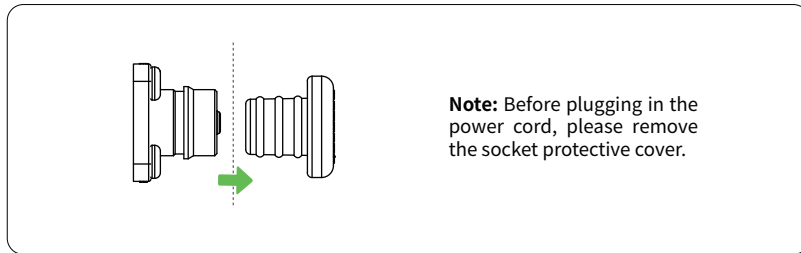

**Note:** Before plugging in the power cord, please remove the socket protective cover.

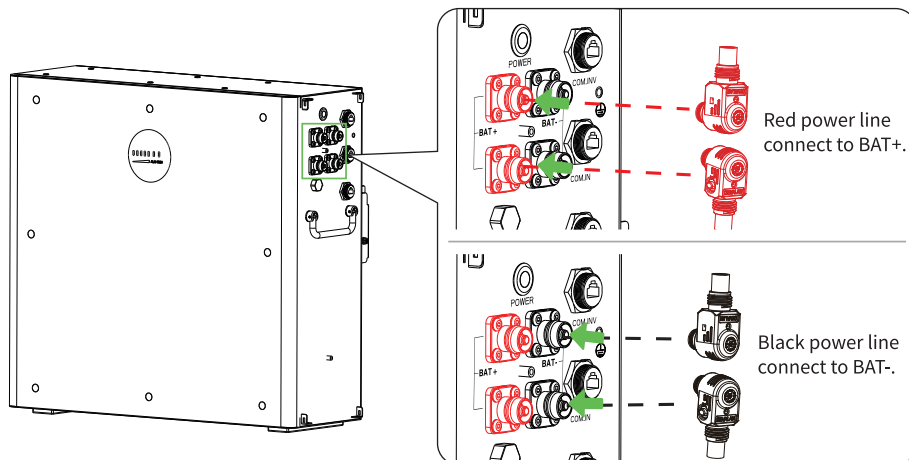

## Communication cable connection

### Note

The three communication cables are different. COM.INV is for inverter communication, COM.IN, COM.OUT for parallel communication.

- Do not use RJ45 cable with protective cover.
- When one battery is applied, insert the RJ45 connector into the COM.INV port.
- When multiple batteries are applied in parallel, connect the communication ports in series by net cables. Connect COM.IN of battery #1 and COM. OUT of #2, COM. IN of #2 and COM.OUT of #3. In such a way, at most 10 batteries shall be connected in parallel.

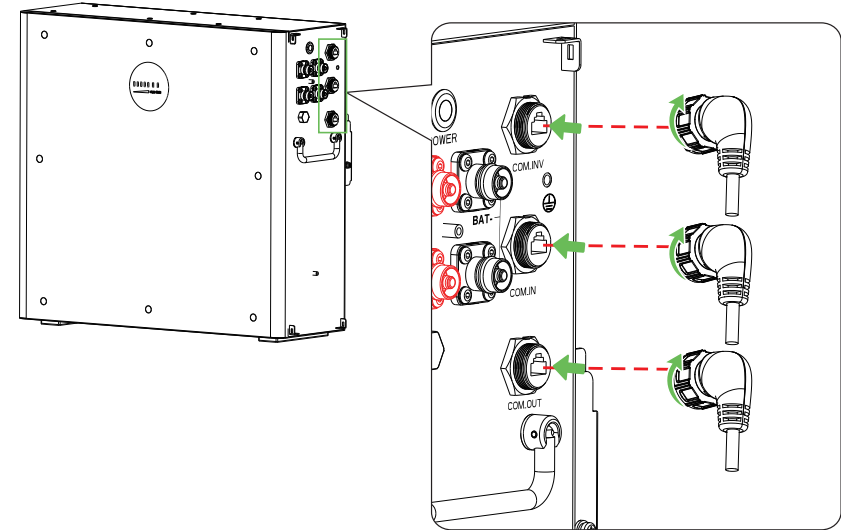

RJ45 communication port

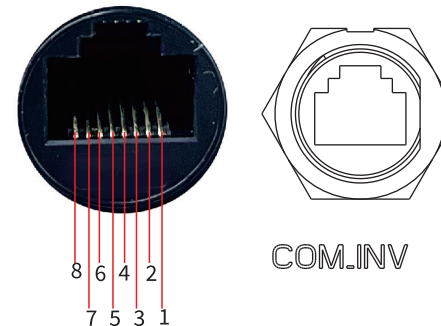

COM\_INV ports definition

| RJ45 PIN   | Definition | Remark |
|--|------------|--------|
| 1  | SLEEP_WKP  |        |
| 2  | GND        |        |
| 3  | NC         | Void   |
| 4  | CANH       |        |
| 5  | CANL       |        |
| 6  | NC         | Void   |
| 7  | RS485-A    |        |
| 8  | RS485-B    |        |
| RJ45 PIN definition for inverter & BMS communication |            |        |

RJ45 communication port

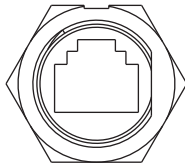
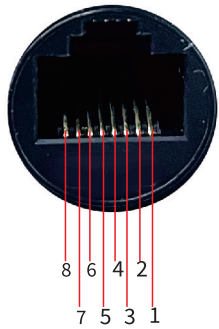

COM.IN

**COM\_IN ports definition**

| RJ45 PIN   | Definition | Remark |
|--|------------|--------|
| 1  | CANL       |        |
| 2  | IUIP       |        |
| 3  | CANH       |        |
| 4  | I_READY    |        |
| 5  | GND        |        |
| 6  | O_WKUP     |        |
| 7  | NC         | Void   |
| 8  | NC         | Void   |
| RJ45 PIN definition for BMS parallel input communication |            |        |

RJ45 communication port

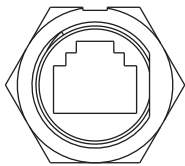
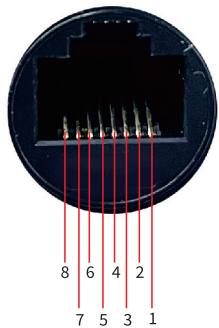

COM.OUT

**COM\_OUT ports definition**

| RJ45 PIN   | Definition | Remark |
|--|------------|--------|
| 1  | CANL       |        |
| 2  | GND        |        |
| 3  | CANH       |        |
| 4  | O_READY    |        |
| 5  | GND        |        |
| 6  | I_WKUP     |        |
| 7  | NC         | Void   |
| 8  | NC         | Void   |
| RJ45 PIN definition for BMS parallel input communication |            |        |

**06 System operation**

**6.1 Check before power on**

Check the following items before power on. Otherwise, the battery system may be damaged.

| No. | Items  |
|-----|--|
| 1   | The equipment is installed firmly in a place where is convenient for operation and maintenance. The installation place is clean and well ventilated. |
| 2   | The ground cable, power cable, communication cable and terminal resistance are connected correctly and securely.                                     |
| 3   | The cable ties meet the cabling requirements and are reasonably distributed. No cables or ties are broken.   |
| 4   | Unused ports are sealed.   |

**6.2 Powering on the Battery System**

**Note**

The circuit breaker between the inverter and the battery and the circuit breaker between the battery and the battery must be installed in accordance with local laws and regulations.

All circuit breakers are to cooperate in all live (a.c. - active and neutral or d.c. - positive and negative) conductors.

The breaker should isolate both positive and negative conductors simultaneously and can ensure that any energized parts are isolated prior to any maintenance, installation, repair or replacement activities.

**Step 1** (Optional) Close the circuit breaker between the inverter and battery system.

**Step 2** (Optional) Close the circuit breaker between the battery and battery system.(When multiple machines are connected in parallel.)

**Step 3** Press the battery button switch. (When using in parallel, just press the battery button switch that communicates with the inverter.)

**Single battery system**

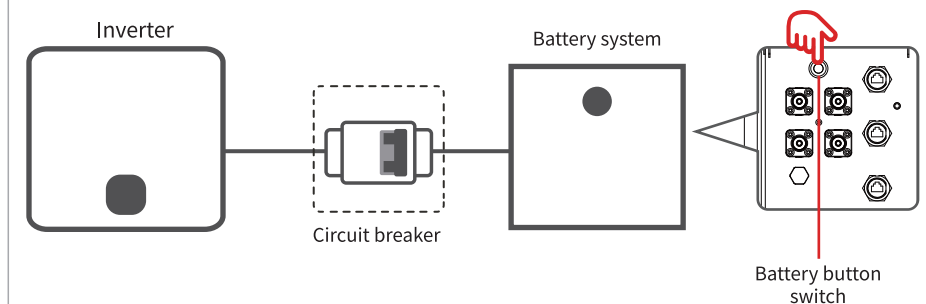

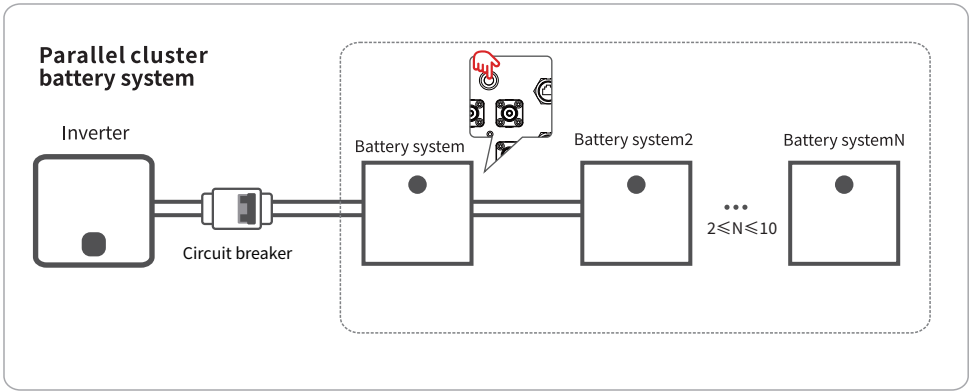

**Low voltage DC miniature circuit breaker (125 series)**

- \*No polarity and bidirectional protection. \*Short circuit protection and overload protection.
- \*High breaking capacity, up to 10kA.
- \*Ui: 500Vdc \*Ue: 80/160Vdc \*In:125A

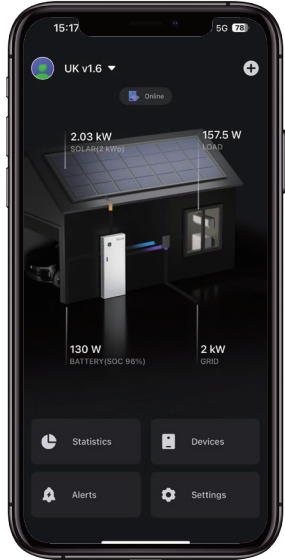
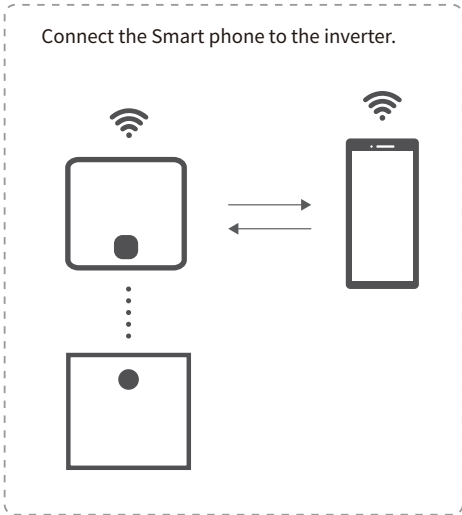

### 6.3 Viewing and Configuring Battery Parameters

After connecting the battery and inverter, use the Hinen App to select the appropriate options for parameter viewing and configuration.

**• APP Installation and Connection:**

**Method 1:**  
Download and install the Hinen App.

**Method 2:**

Hinen INSTALL      Hinen SOLAR

**• Viewing Battery Parameter**

Tap the inverter connected with battery to enter the corresponding interface and check the battery parameter.

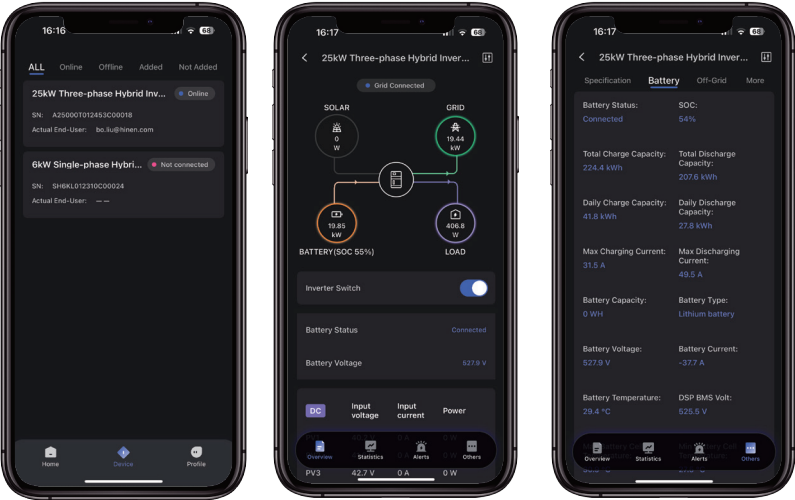

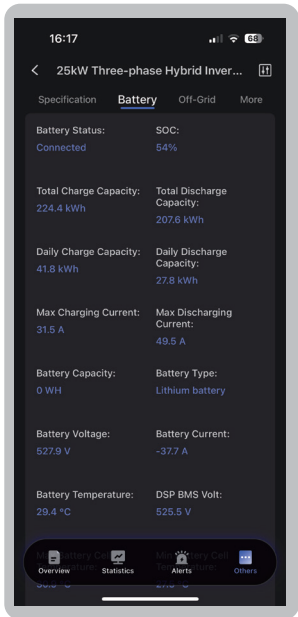

## Battery

Here is the battery information: battery status, battery type, main battery voltage, slave battery voltage, battery capacity, battery charging power, battery discharging power, battery SOC, battery SOH, total charge capacity, total discharge capacity, daily charge capacity, daily discharge capacity, and so on.

- Select battery protocol

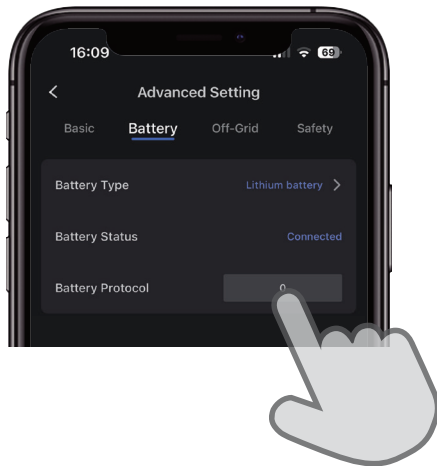

Enter the correct battery protocol and click "Save".

| Battery Protocol |                       |                      |
|------------------|-----------------------|----------------------|
|                  | Single-phase Inverter | Three-phase Inverter |
| 0                |                       | PYLON Protocol       |
| 1                |                       | HINEN Protocol       |
| 2                |                       | Growatt Protocol     |
| 3                |                       | Growcol Protocol     |
| 4                |                       | SHOTO Protocol       |
| 5                |                       | GoodWE Protocol      |
| 6                |                       | YUZEI Protocol       |
| 7-20             |                       | Battery 7~20         |

**Warning:** Please choose the correct battery protocol. Otherwise the battery system will not work normally.

You can check and configure parameters by Solarman Smart.



SOLARMAN Business



SOLARMAN Smart



Solarman Manual

<https://www.hinen.com/pages/smart-energy-management-system>

## 6.4 Indicator status

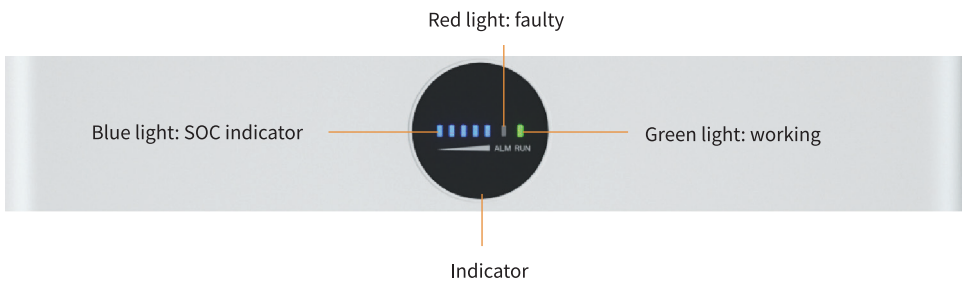

| Indicator   | Status           |
|-------------|------------------|
| Green light | Standby, working |
| Red light   | Alert, faulty    |
| Blue light  | SOC indicator    |

### 6.4.1 Normal state

| SOC indicator | Description  |
|---------------|--------------|
|               | 0%<SOC<20%   |
|               | 20%<SOC<40%  |
|               | 40%<SOC<60%  |
|               | 60%<SOC<80%  |
|               | 80%<SOC<100% |

If the battery does not work properly, press and hold the power switch button for 10s to reset.

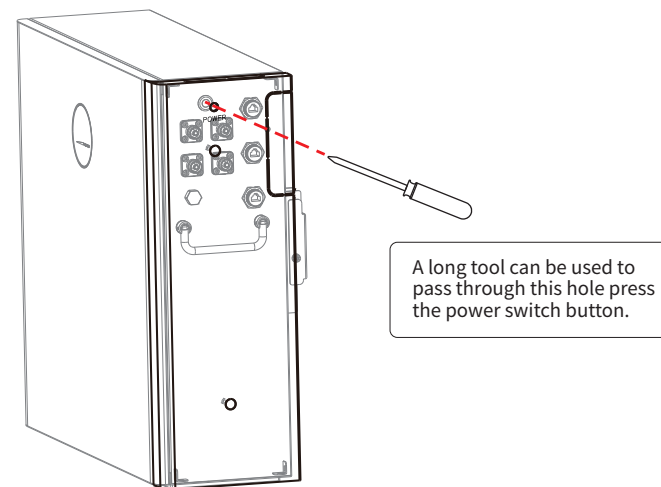

A long tool can be used to pass through this hole press the power switch button.

### 6.4.2 Alert State

| Indicator status | SOC indicator | Alarm Description                    | Solution   |
|------------------|---------------|--------------------------------------|--|
| Red light blinks |               | Cell over voltage                    | Restart the battery. If it's still not fixed, contact customer service.  |
|                  |               | Cell voltage difference too large    | Charge the battery, waiting for the voltage to recover.  |
|                  |               | Cell under voltage                   |  |
|                  |               | Battery under voltage                |  |
|                  |               | Battery over voltage                 |  |
|                  |               | Battery over temperature             | Turn off and wait for 2 hours. If it's still not fixed, contact customer service.                                  |
|                  |               | Battery low temperature              | Turn off, wait the temperature to recover, restart the battery. If it's still not fixed, contact customer service. |
|                  |               | Overcurrent when charging            | Restart the battery. If it's still not fixed, contact customer service.  |
|                  |               | Overcurrent when discharging 1       |  |
|                  |               | Overcurrent when discharging 2       |  |
|                  |               | Short when discharging               | Turn off, remove and check equipment, restart the battery. If it's still not fixed, contact customer service.      |
|                  |               | Short when charging                  |  |
|                  |               | PCB over temperature                 | Turn off and wait for 2 hours. If it's still not fixed, contact customer service.                                  |
|                  |               | Pre-charge resistor over temperature |  |
|                  |               | MOS temperature is too high          | Charge the battery, waiting for the voltage to recover.  |
|                  |               | IUIP parallel signal fault           | Turn off, check the communication cable, restart the battery. If it's still not fixed, contact customer service.   |
|                  |               | I_WORK parallel signal fault         |  |
|                  |               | Parallelization over time            |  |
|                  |               | Parallelization readiness failure    |  |

| Indicator status | SOC indicator | Alarm Description                              | Solution  |
|------------------|---------------|--|---|
| Red light blinks |               | The version difference is too large            | Upgrade the low version battery pack separately to the latest version, reconnect the communication cable after the upgrade is complete, and the alarm disappears. |
|                  |               | Mixing regular batteries with heated batteries | Replace the corresponding battery to maintain consistency in battery type.  |

### Remark

- It is recommended to restart by the switch button.
- When running in parallel, after the battery under-voltage protection and under-voltage protection are powered off, just click the battery button switch that communicates with the inverter to force activation.

### 6.4.3 Fault State

| Indicator status    | SOC indicator | Fault Description                           | Solution   |
|---------------------|---------------|---|--|
| Red light always on |               | Battery voltage sampling wire broken        | Restart the battery. If it's still not fixed, contact customer service.  |
|                     |               | MOS failure                                 |  |
|                     |               | AFE communication failure                   |  |
|                     |               | EEPROM failure                              |  |
|                     |               | Voltage sensor failure                      | Contact customer service.  |
|                     |               | Extremely high battery voltage fault        |  |
|                     |               | Main circuit fault                          |  |
|                     |               | Pre-charge over time                        | Restart the battery. If it's still not fixed, contact customer service.  |
|                     |               | Current sensor failure                      |  |
|                     |               | Dead battery                                |  |
|                     |               | Inverter communication timeout              | Check if the communication cable is properly connected, verify the inverter protocol settings, and confirm that the inverter-side battery mode is set to lithium battery mode. |
|                     |               | CAN bus failure                             | Turn off, check the communication cable. If it's still not fixed, contact customer service.  |
|                     |               | RS485 bus failure                           |  |
|                     |               | Parallel address recognition failure        |  |
|                     |               | Short circuit protection fuse circuit fault | Contact customer service.  |

|                     |   |                                 |  |
|---------------------|---|---------------------------------|--|
| Red light always on |  | NTC Sampling Line Disconnection | Check if the sampling line on the BMS board has poor contact.<br>If there is no poor contact with the sampling line on the BMS board, the device needs to be replaced. |
|---------------------|---|---------------------------------|--|

### 6.5 Powering off the Battery System

Please follow the steps to power off the Battery System, otherwise, the System may be damaged.

**Step 1** Press the power button for more than 3 seconds until the indicator lights off. If multiple batteries are connected, press only the battery power button that communicates with the inverter.

**Step 2** Disconnect the circuit breakers of all batteries.

**Step 3** Make sure that the SOC indicator of the battery is off.

#### Single battery system

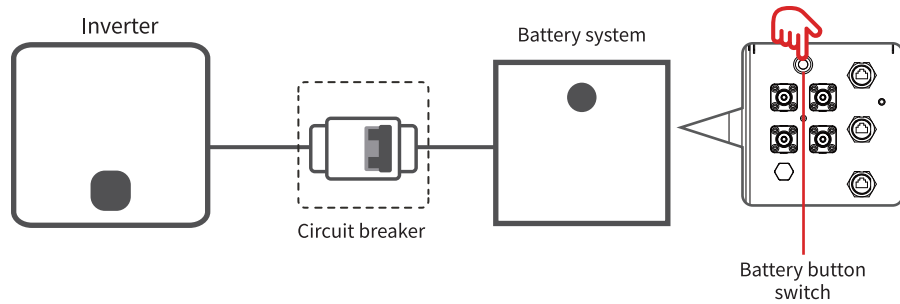

#### Parallel cluster battery system

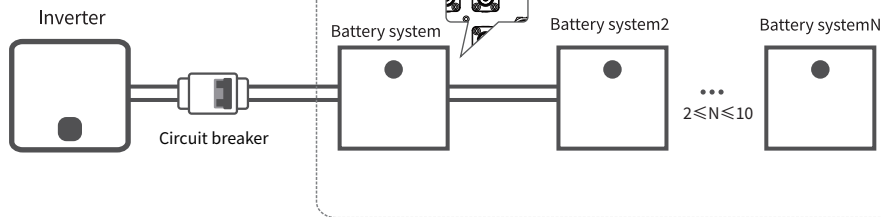

#### Low voltage DC miniature circuit breaker (125 series)

- \*No polarity and bidirectional protection.    \*Short circuit protection and overload protection.
- \*High breaking capacity, up to 10kA.
- \*Ui: 500Vdc    \*Ue: 80/160Vdc    \*In:125A

## 07 Maintenance

| Item  | Period              |
|---|---------------------|
| Fully charge the battery and discharge it to 25-50% if the battery is not in use.                                   | Once every 3 months |
| Check the wall mounting plate, fix it if it is not secured.   | Once every 6 months |
| Check whether the outer shell is broken. Repair the painting or contact after-sales service if there is any broken. | Once every 6 months |
| Check whether there is an exposed cable. Replace the exposed cable or contact after-sales service for help.         | Once every 6 months |
| Check whether there is debris accumulation around the battery to avoid affecting heat dissipation.                  | Once every 6 months |
| Check for water and pest to avoid prolonged intrusion.  | Once every 6 months |

#### Warning!

- Please contact after-sales for help if you find any problems that may influence the battery or the inverter. Disassemble without permission is strictly forbidden.
- Please contact after-sales for help if the conductive wire is exposed because high voltage danger exists. Do not touch or disassemble privately.
- In case of other emergencies, contact the after-sales as soon as possible. Please operate following the guidance of the after-sales, or just wait for the after-sales service operators.

## 08 Technical parameters

Rated Energy<sup>1</sup>: Test conditions, Fresh battery, 0.33C charge & discharge at +25°C.

Cycle life<sup>2</sup>: Test conditions, 90%DOD, 0.2C charge & discharge at +25°C.

Warranty<sup>3</sup>: Refer to the product warranty terms for details.

### 8.1 Standard Battery System

| Model                                      | B5000  | B5000x2                                     | B5000x3                                     | B5000x4                                     | B5000x5                                    | B5000x6                                     | B5000x7                                     | B5000x8                                     | B5000x9                                     | B5000x10                                   |
|--|--|---|---|---|--|---|---|---|---|--|
| Product name                               | Rechargeable Li-ion Battery Pack (5.12kWh)           | Rechargeable Li-ion Battery Pack (10.24kWh) | Rechargeable Li-ion Battery Pack (15.36kWh) | Rechargeable Li-ion Battery Pack (20.48kWh) | Rechargeable Li-ion Battery Pack (25.6kWh) | Rechargeable Li-ion Battery Pack (30.72kWh) | Rechargeable Li-ion Battery Pack (35.84kWh) | Rechargeable Li-ion Battery Pack (40.96kWh) | Rechargeable Li-ion Battery Pack (46.08kWh) | Rechargeable Li-ion Battery Pack (51.2kWh) |
| Rated Energy <sup>1</sup>                  | 5.12kWh  | 10.24kWh                                    | 15.36kWh                                    | 20.48kWh                                    | 25.6kWh                                    | 30.72kWh                                    | 35.84kWh                                    | 40.96kWh                                    | 46.08kWh                                    | 51.2kWh                                    |
| Usable capacity                            | 4.6kWh   | 9.21kWh                                     | 13.82kWh                                    | 18.43kWh                                    | 23.04kWh                                   | 27.64kWh                                    | 32.26kWh                                    | 36.86kWh                                    | 41.47kWh                                    | 46.08kWh                                   |
| Battery type                               | LFP(LiFePO <sub>4</sub> )                            |   |   |   |  |   |   |   |   |  |
| Battery configuration                      | 16S1P  | 16S2P                                       | 16S3P                                       | 16S4P                                       | 16S5P                                      | 16S6P                                       | 16S7P                                       | 16S8P                                       | 16S9P                                       | 16S10P                                     |
| Maximum modules in parallel                | 10   |   |   |   |  |   |   |   |   |  |
| Cycle life <sup>2</sup>                    | 8000 cycles  |   |   |   |  |   |   |   |   |  |
| Rated voltage                              | 51.2 V   |   |   |   |  |   |   |   |   |  |
| Operating voltage range                    | 48-58V   |   |   |   |  |   |   |   |   |  |
| Peak current                               | 120A 60S   |   |   |   |  |   |   |   |   |  |
| Depth of Discharge (DOD)                   | 90%  |   |   |   |  |   |   |   |   |  |
| Max. continuous charge / discharge current | 100A   |   |   |   |  |   |   |   |   |  |
| Rated power                                | 5.12KW   |   |   |   |  |   |   |   |   |  |
| Short-Circuit Current                      | 800A@0.1mS   |   |   |   |  |   |   |   |   |  |
| Run Log Recording                          | 32M-byte   |   |   |   |  |   |   |   |   |  |
| Communication                              | CAN  |   |   |   |  |   |   |   |   |  |
| Weight                                     | 51.8KG (±3KG)  | 103.6KG (±3KG)                              | 155.4KG (±3KG)                              | 207KG (±3KG)                                | 259KG (±3KG)                               | 310.8KG (±3KG)                              | 362.6KG (±3KG)                              | 414.4KG (±3KG)                              | 466.2KG (±3KG)                              | 518KG (±3KG)                               |
| Dimensions (W*H*D)                         | 579*500*175mm  | 579*1000*175mm                              | 579*1500*175mm                              | (579*1000*175mm) x2                         | 579*1500*175mm<br>579*1000*175mm           | (579*1500*175mm) x2                         | 579*2000*175mm<br>579*1500*175mm            | (579*2000*175mm) x2                         | 579*2500*175mm<br>579*2000*175mm            | (579*2500*175mm) x2                        |
| Operating temperature                      | Charge: 0°C < T < 55°C / Discharge: -20°C < T < 55°C |   |   |   |  |   |   |   |   |  |
| Storage temperature                        | -20~40°C (≤ One month) / 0~35°C (≤ One year)         |   |   |   |  |   |   |   |   |  |
| Humidity                                   | ≤ 10~85%   |   |   |   |  |   |   |   |   |  |
| Altitude                                   | ≤ 2000m  |   |   |   |  |   |   |   |   |  |
| Ingress protection rating                  | IP65   |   |   |   |  |   |   |   |   |  |
| Installation type                          | Wall-mounted / Floor stand                           |   |   |   |  |   |   |   |   |  |
| Warranty <sup>3</sup>                      | 10 Years Warranty, 10 Years Performance Life         |   |   |   |  |   |   |   |   |  |
| Country of manufacture                     | Made in China  |   |   |   |  |   |   |   |   |  |

## 8.2 Battery System with Heating Function

Rated Energy<sup>1</sup>: Test conditions, Fresh battery, 0.33C charge & discharge at +25°C.

Cycle life<sup>2</sup>: Test conditions, 90%DOD, 0.2C charge & discharge at +25°C.

Warranty<sup>3</sup>: Refer to the product warranty terms for details.

| Model                                      | B5000-W                                      | B5000-Wx2                                   | B5000-Wx3                                   | B5000-Wx4                                   | B5000-Wx5                                  | B5000-Wx6                                   | B5000-Wx7                                   | B5000-Wx8                                   | B5000-Wx9                                   | B5000-Wx10                                 |
|--|--|---|---|---|--|---|---|---|---|--|
| Product name                               | Rechargeable Li-ion Battery Pack (5.12kWh)   | Rechargeable Li-ion Battery Pack (10.24kWh) | Rechargeable Li-ion Battery Pack (15.36kWh) | Rechargeable Li-ion Battery Pack (20.48kWh) | Rechargeable Li-ion Battery Pack (25.6kWh) | Rechargeable Li-ion Battery Pack (30.72kWh) | Rechargeable Li-ion Battery Pack (35.84kWh) | Rechargeable Li-ion Battery Pack (40.96kWh) | Rechargeable Li-ion Battery Pack (46.08kWh) | Rechargeable Li-ion Battery Pack (51.2kWh) |
| Rated Energy <sup>1</sup>                  | 5.12kWh                                      | 10.24kWh                                    | 15.36kWh                                    | 20.48kWh                                    | 25.6kWh                                    | 30.72kWh                                    | 35.84kWh                                    | 40.96kWh                                    | 46.08kWh                                    | 51.2kWh                                    |
| Usable capacity                            | 4.6kWh                                       | 9.21kWh                                     | 13.82kWh                                    | 18.43kWh                                    | 23.04kWh                                   | 27.64kWh                                    | 32.26kWh                                    | 36.86kWh                                    | 41.47kWh                                    | 46.08kWh                                   |
| Battery type                               | LFP(LiFePO <sub>4</sub> )                    |   |   |   |  |   |   |   |   |  |
| Battery configuration                      | 16S1P  | 16S2P                                       | 16S3P                                       | 16S4P                                       | 16S5P                                      | 16S6P                                       | 16S7P                                       | 16S8P                                       | 16S9P                                       | 16S10P                                     |
| Maximum modules in parallel                | 10   |   |   |   |  |   |   |   |   |  |
| Cycle life <sup>2</sup>                    | 8000 cycles                                  |   |   |   |  |   |   |   |   |  |
| Rated voltage                              | 51.2 V                                       |   |   |   |  |   |   |   |   |  |
| Operating voltage range                    | 48-58V                                       |   |   |   |  |   |   |   |   |  |
| Peak current                               | 120A 60S                                     |   |   |   |  |   |   |   |   |  |
| Depth of Discharge (DOD)                   | 90%  |   |   |   |  |   |   |   |   |  |
| Max. continuous charge / discharge current | 100A   |   |   |   |  |   |   |   |   |  |
| Rated power                                | 5.12KW                                       |   |   |   |  |   |   |   |   |  |
| Short-Circuit Current                      | 800A@0.1mS                                   |   |   |   |  |   |   |   |   |  |
| Run Log Recording                          | 32M-byte                                     |   |   |   |  |   |   |   |   |  |
| Communication                              | CAN  |   |   |   |  |   |   |   |   |  |
| Weight                                     | 51.8KG (±3KG)                                | 103.6KG (±3KG)                              | 155.4KG (±3KG)                              | 207KG (±3KG)                                | 259KG (±3KG)                               | 310.8KG (±3KG)                              | 362.6KG (±3KG)                              | 414.4KG (±3KG)                              | 466.2KG (±3KG)                              | 518KG (±3KG)                               |
| Dimensions (W*H*D)                         | 579*500*175mm                                | 579*1000*175mm                              | 579*1500*175mm                              | (579*1000*175mm) x2                         | 579*1500*175mm<br>579*1000*175mm           | (579*1500*175mm) x2                         | 579*2000*175mm<br>579*1500*175mm            | (579*2000*175mm) x2                         | 579*2500*175mm<br>579*2000*175mm            | (579*2500*175mm) x2                        |
| Operating temperature                      | Charge / Discharge: -20°C<T<55°C             |   |   |   |  |   |   |   |   |  |
| Storage temperature                        | -20~40°C (≤ One month) / 0~35°C (≤ One year) |   |   |   |  |   |   |   |   |  |
| Humidity                                   | ≤ 10~85%                                     |   |   |   |  |   |   |   |   |  |
| Altitude                                   | ≤ 2000m                                      |   |   |   |  |   |   |   |   |  |
| Ingress protection rating                  | IP65   |   |   |   |  |   |   |   |   |  |
| Installation type                          | Wall-mounted / Floor stand                   |   |   |   |  |   |   |   |   |  |
| Warranty <sup>3</sup>                      | 10 Years Warranty, 10 Years Performance Life |   |   |   |  |   |   |   |   |  |
| Country of manufacture                     | Made in China                                |   |   |   |  |   |   |   |   |  |

