

Low Voltage Battery

# USER MANUAL

---

LB-16D-G2

## Legal Notice

Hoymiles has made every effort to ensure the accuracy and completeness of this manual. However, this manual may be changed and revised due to product enhancements or user feedback.

Hoymiles reserves the right to modify this manual without prior notice at any given time. The latest version of this manual can be found by visiting the Hoymiles official website [www.hoymiles.com](http://www.hoymiles.com) or scanning the QR Code below.



## Warranty

Follow the installation instructions in this manual to ensure warranty compliance and reliability. The current warranty conditions can be accessed at [www.hoymiles.com](http://www.hoymiles.com).

## Contact Information

If you have technical queries or any questions concerning our products, please contact our support through the Hoymiles service portal:



### Germany

[service.de@hoymiles.com](mailto:service.de@hoymiles.com)

### Italy

[service.it@hoymiles.com](mailto:service.it@hoymiles.com)

### Poland

[service.pl@hoymiles.com](mailto:service.pl@hoymiles.com)

### Other EU countries

[service.eu@hoymiles.com](mailto:service.eu@hoymiles.com)

### Spain

[service.es@hoymiles.com](mailto:service.es@hoymiles.com)

### Netherlands

[service.nl@hoymiles.com](mailto:service.nl@hoymiles.com)

### Finland

[service.fi@hoymiles.com](mailto:service.fi@hoymiles.com)

### Australia & New Zealand

[service.au@hoymiles.com](mailto:service.au@hoymiles.com)

### France

[service.fr@hoymiles.com](mailto:service.fr@hoymiles.com)

### Norway

[service.no@hoymiles.com](mailto:service.no@hoymiles.com)

### Austria

[service.at@hoymiles.com](mailto:service.at@hoymiles.com)

### Asia & Pacific

[service.asia@hoymiles.com](mailto:service.asia@hoymiles.com)



### Germany

+49 6994322186

### Poland

+48 918821656

### France

+33 159131589

### Netherlands

+31 852736388



[hoymiles.com](http://www.hoymiles.com)

# Contents

<b>1</b>	<b>About This Manual</b>	<b>5</b>
1.1	Purpose	5
1.2	Audience	5
1.3	Validity	5
<b>2</b>	<b>Safety Information</b>	<b>6</b>
2.1	Safety Symbols	6
2.2	Additional Symbols	6
2.3	Intended Use	7
2.4	Safety Instructions	7
<b>3</b>	<b>Transportation and Storage</b>	<b>9</b>
3.1	Transportation Requirements	9
3.2	Storage Requirements	9
<b>4</b>	<b>Product Introduction</b>	<b>10</b>
4.1	Product Overview	10
4.2	LED Indicators	11
4.3	DIP Switch Instructions	12
<b>5</b>	<b>System Overview</b>	<b>13</b>
5.1	Single Battery System	13
5.2	Multi-battery System	14
<b>6</b>	<b>Installation Instructions</b>	<b>16</b>
6.1	Unpacking	16
6.2	Environmental Requirements	16
6.3	Space Requirements	17
6.4	Installation Tools	17
6.5	Installation Steps	18
<b>7</b>	<b>Electrical Connection</b>	<b>20</b>
7.1	Single battery System	20
7.1.1	Ground Cable Connection	20
7.1.2	Power Cable Connection	21
7.1.3	Communication Cable Connection	21
7.2	Multi-battery System	22
7.2.1	Ground Cable Connection	22
7.2.2	Power Cable Connection	22
7.2.3	Communication Cable Connection	23
<b>8</b>	<b>System Commissioning</b>	<b>24</b>
8.1	Preparation	24
8.2	System Power-on	24
<b>9</b>	<b>System Maintenance</b>	<b>25</b>
9.1	System Power-off	25
9.2	Routine Maintenance	25
9.3	Troubleshooting	26

<b>10</b>	<b>Decommissioning .....</b>	<b>27</b>
10.1	Removing the Product .....	27
10.2	Packing the Product .....	27
10.3	Disposing of the Product .....	27
<b>11</b>	<b>Handling Precautions and Guidelines for Product.....</b>	<b>28</b>
<b>12</b>	<b>Technical Datasheet.....</b>	<b>30</b>

# 1 About This Manual

## 1.1 Purpose

This manual provides information on the installation, electrical connections, operation, and maintenance of the LB-16D-G2 series battery.

Please consider the following before installation:

- Carefully read this manual before operation.
- Keep this manual for reference.

## 1.2 Audience

This manual is intended for use by qualified persons only. Qualified persons must have the following skills:

- Knowledge of how a battery works.
- Knowledge of how an inverter works.
- Training in how to deal with the dangers and risks associated with the installation, maintenance, and use of electrical devices.
- Training in the installation, commissioning, and maintenance of electrical devices.
- Knowledge of and compliance with all applicable laws, standards, and directives.

## 1.3 Validity

This manual is valid for LB-16D-G2.

### **NOTE**

*Model identifier:*

**LB - 16D - G2**  
**T TT T**  
**A BC D**

[A]: Series Name (Low Voltage Battery)

[B]: Total Energy (16.08 kWh)

[C]: Battery Type (Detached Battery)





[D]: Generation (The Second Generation)

## 2 Safety Information

The LB-16D-G2 series battery is designed and tested according to international safety requirements. However, certain safety precautions must be taken while installing, operating, and maintaining the battery. Please carefully read all safety instructions before installation, and observe all these safety instructions.







### 2.1 Safety Symbols

Safety symbols are used in this manual as follows:

Symbol	Description
 <b>DANGER</b>	This symbol indicates potential risks that, if not avoided, may lead to death or serious physical injury.
 <b>WARNING</b>	This symbol indicates potential risks that, if not avoided, may lead to personal injury or device damage.
 <b>CAUTION</b>	This symbol indicates potential risks that, if not avoided, may lead to device malfunctions or financial losses.
 <b>NOTICE</b>	This symbol indicates potential risks that, if not avoided, may lead to minor injury or damage to the equipment.
 <b>NOTE</b>	This symbol indicates an important step or tip that leads to the best results but is not safety- or damage-related.

### 2.2 Additional Symbols

The product label contains the following symbols with their meanings described below:

Symbol	Usage
	<b>Electric hazard</b> This symbol indicates that there is a danger of electric shock. Failure to pay attention to the procedures, practices, or improper implementation may cause injuries or death.
	The product must be stored and installed far from flammable materials.
	WEEE Designation. Do not dispose of the product together with household waste. Dispose of the product in accordance with local disposal regulations for electronic waste.
	CE mark. The product complies with the requirements of the applicable EU directives.
	The battery can be used only indoors.
	Observe the documentation. Read and understand all documentation supplied with the product.

## 2.3 Intended Use

The LB-16D-G2 series is a BESS which is for residential applications.

- It is a low voltage Li-ion BESS.
- It can be installed indoors. For details, refer to [6.2 Environmental Requirements](#).
- It must only be used as stationary equipment.
- Alterations to the product are not allowed unless authorized in writing by the supplier.
- Unauthorized alterations will void the guarantee and warranty claims. Hoymiles will not be liable for any damage caused by such unauthorized alterations.
- It is not suitable for supplying power to life-sustaining medical devices.
- Please ensure that there will be no personal injury due to the power outage of the battery system.
- It can only be used in countries where it is approved by battery suppliers.
- It should be used in accordance with the information provided in this document and local applicable standards and directives. Any other application may cause personal injury or property damage.
- The label must be permanently attached to the product.
- The safety instructions in this document are only supplements to local laws and regulations. Please follow local laws and regulations during installation, operation, and maintenance.

## 2.4 Safety Instructions

To prevent personal injury and property damage and to ensure the long-term operation of the product, read this section carefully and observe all safety information at all times. Failure to observe the prescribed instructions may potentially void the manufacturer's warranty. If in doubt, please contact Hoymiles.

### DANGER

#### **Danger to life due to electric shock where surge protection is not used!**

If there is no surge protection, a voltage surge can be conducted into the building and to other connected devices in the same system through power cables, network cables, or other cables. Touching live parts and cables may result in death or lethal injury due to electric shock.

- Ensure all devices in the same system and the inverter are integrated with an existing surge protection system or device.
- Install the surge protection device in accordance with local laws and regulations.

### WARNING

#### **Danger to life due to overvoltage!**

Overvoltage can damage a measurement device and result in voltage being present in the enclosure of the measurement device. Touching the live enclosure of the measuring device will result in death or lethal injuries due to electric shock.

- Only use measurement devices with a voltage range higher than the system battery voltage.
- Do not touch hot surfaces before it cools down.

#### **Risk of injury due to the weight of the product!**

- If the product is lifted incorrectly or dropped while being transported or mounted, it may result in injury.
- Lift and transport the product carefully.
- Wear suitable personal protective equipment, and comply with local regulations during installation, operation, and maintenance.

**⚠ WARNING****Fire hazard!**

- If the fire is not from the battery or not spread to the battery, please use FM-200 or a carbon dioxide fire extinguisher to put out the fire.
- If the battery pack catches fire, do not attempt to put out the fire and evacuate immediately. Keep damaged batteries isolated and call the local fire department. Immediately seek medical in case of breathing in toxic fumes.

**Keep away from water!**

- Keep the battery packs away from water. If any part of the battery system is submerged, there is a risk of electric shock and internal short-circuit.
- Do not reuse the battery if it has been submerged in water.

**NOTICE****Damage to the battery system due to electrostatic discharge!**

Internal components of the battery system can be irreparably damaged by electrostatic discharge.

Ground yourself before touching any component.

## 3 Transportation and Storage

### 3.1 Transportation Requirements

- The battery has been certified to UN 38.3 and passed related tests. As it is classified as class 9 dangerous goods, it must be transported in accordance with specific regulations.
- Batteries must be transported separately.
- Ensure that the packages, labels, and other markings are correct and intact before and during transportation.
- During transportation, keep the battery in its correct direction in case it falls.
- The battery should be carefully transported to avoid short circuits, damage, fire, or explosion, and to ensure personal safety.
- Pay attention to the weight of the product to avoid injury when handling the product.
- Do not hold the terminals or cables to move a battery.
- Wear personal protective equipment when handling the batteries.
- Personnel working with batteries must be well trained in proper lifting and handling procedures.

### 3.2 Storage Requirements

Suitable storage is required if the battery is not installed immediately.

- Store the battery in the original package, and do not unpack the battery.
- It is recommended to store the product in an environment with a temperature between 15°C and 35°C and a relative humidity between 10% and 95%, without condensing.
- The package with the battery shall not be tilted or inverted.
- Do not place any objects on the top of the battery pack.
- The battery should be stored in a cool and clean place where it can be protected from direct sunlight and bad weather such as rain, snow, or lightning.
- Keep the package away from flammable, explosive, and corrosive materials.
- If the battery has been stored for three months or longer, it must be fully inspected and tested by authorized personnel before it can be put into operation.
- The battery SOC should be 45%-50%. The battery needs to be recharged every 6 months if it is not used, and it is recommended to store it after it is first charged to 100%, then discharged to 50%, and finally powered off.
- The battery needs to be maintained at a maximum interval of 6 months.
- The requirements for the recharge interval after the battery is fully discharged are as follows.
  - a) If the environmental temperature is 45°C-50°C, it should be recharged within 7 days;
  - b) If the environmental temperature is 35°C-45°C, it should be recharged within 15 days;
  - c) If the environmental temperature is no more than 35°C, it should be recharged within 30 days.
- When the device is unused, the battery SOC should be 45%-55%, and the battery output should be disconnected to prevent the battery from draining.
- During the storage period of the system, professionals should regularly check the system to check whether the cables are loose, and clean the surface of the system; if any defects are found, please contact the dealer in time.

# 4 Product Introduction

## 4.1 Product Overview

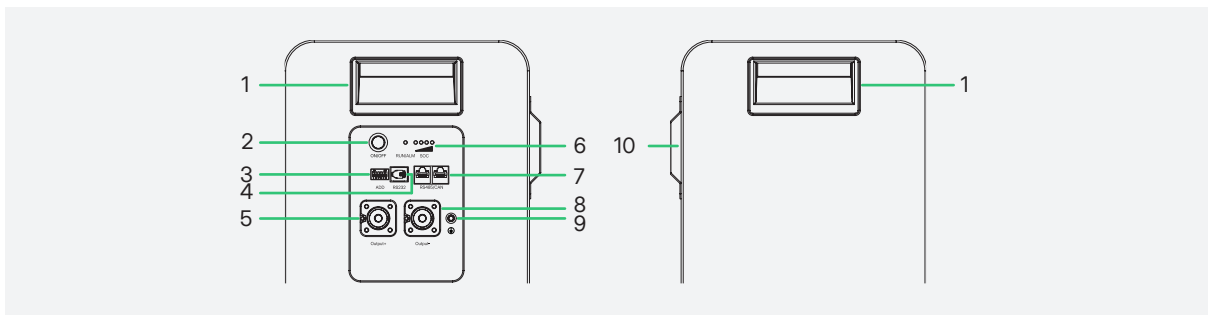
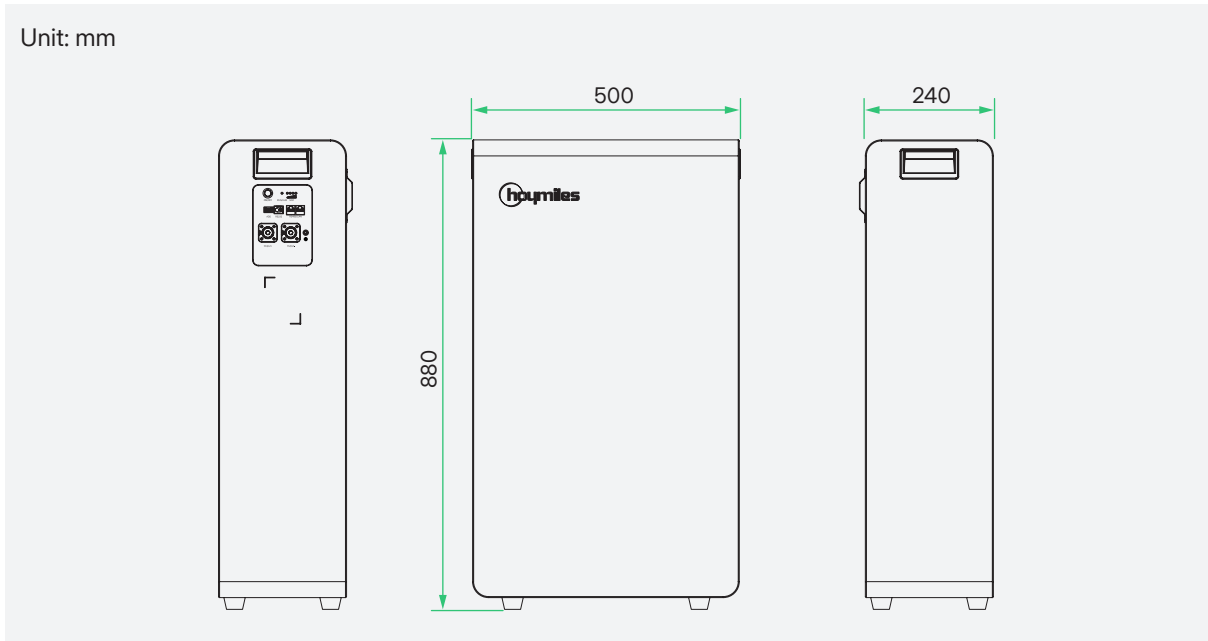

NO.	Description
1	Handle
2	Power Switch
3	DIP Switch
4	Communication Terminal (RS232)
5	Positive Terminal
6	LED Indicators (Run, Alarm, and SOC)
7	Communication Terminals (CAN)
8	Negative Terminal
9	Ground Terminal
10	Mounting Bracket

BAT RJ45 PIN	1	2	3	4	5	6	7	8	INV PIN
	RS485 2_A	RS485 2_B	NC	RS485 1_A	CAN_L	CAN_H	RS485 1_B	NC	

## 4.2 LED Indicators

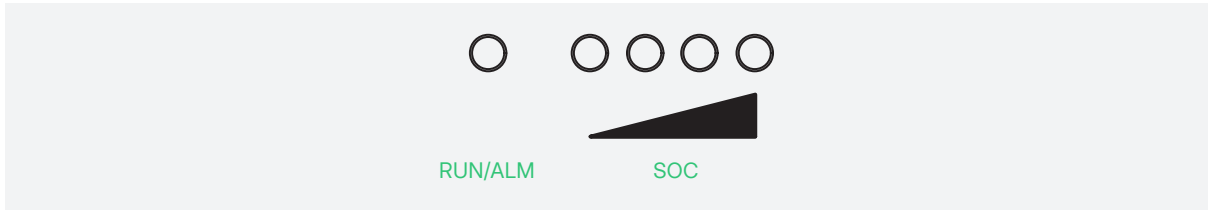

Indicator	Status	Explanation
	Flashing green (on for 0.25s; off for 3.75s).	The battery is in standby.
	Flashing green (on for 0.5s; off for 0.5s).	The battery is charging.
	Solid green	The battery is discharging.
	Flashing red (on for 0.5s; off for 0.5s).	Undervoltage protection and undertemperature protection
	Solid red	A fault occurs.
	Off	The battery is turned off.
	1/4 LED indicator on.	SOC is 0-25%.
	2/4 LED indicators on.	SOC is 25%-50%.
	3/4 LED indicators on.	SOC is 50%-75%.
	All LED indicators on.	SOC is 75%-100%.

### 4.3 DIP Switch Instructions

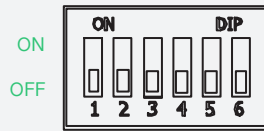

DIP 1	DIP 2	DIP 3	DIP 4	BMS Address	Battery
OFF	OFF	OFF	OFF	0	Master
ON	OFF	OFF	OFF	1	Slave 1
OFF	ON	OFF	OFF	2	Slave 2
ON	ON	OFF	OFF	3	Slave 3
OFF	OFF	ON	OFF	4	Slave 4
ON	OFF	ON	OFF	5	Slave 5
OFF	ON	ON	OFF	6	Slave 6
ON	ON	ON	OFF	7	Slave 7
OFF	OFF	OFF	ON	8	Slave 8
ON	OFF	OFF	ON	9	Slave 9
OFF	ON	OFF	ON	10	Slave 10
ON	ON	OFF	ON	11	Slave 11
OFF	OFF	ON	ON	12	Slave 12
ON	OFF	ON	ON	13	Slave 13
OFF	ON	ON	ON	14	Slave 14
ON	ON	ON	ON	15	Slave 15

**NOTE**  
 Leave DIP 5 and DIP 6 as default.

## 5 System Overview

### NOTICE

It is recommended that a circuit breaker between the inverter and the battery be installed in accordance with local laws and regulations.

### 5.1 Single Battery System

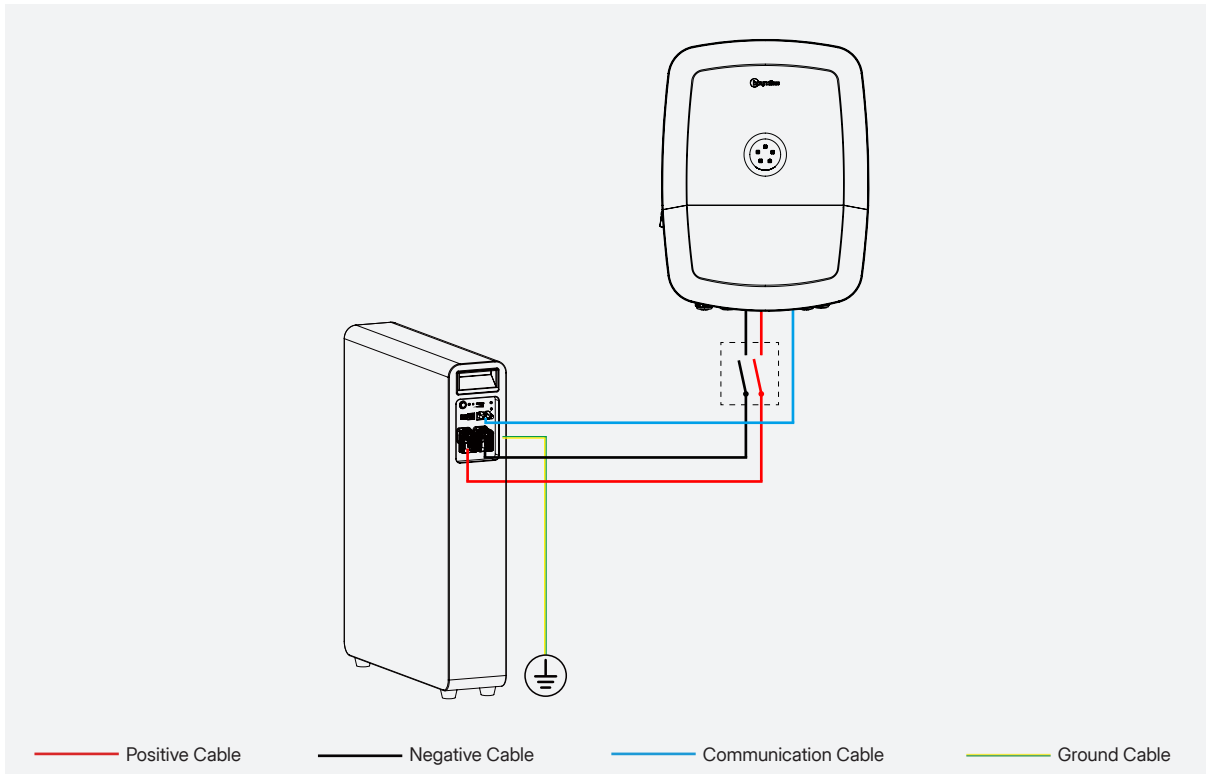

### NOTE

- The maximum charging or discharging current of the battery is 200 A. If the current exceeds 200 A, it may cause a risk of fire.
- Insert the provided 120  $\Omega$  RJ45 connector into the unused communication terminal.

## 5.2 Multi-battery System

### Parallel Connection Without Busbar (Number of Batteries=2)

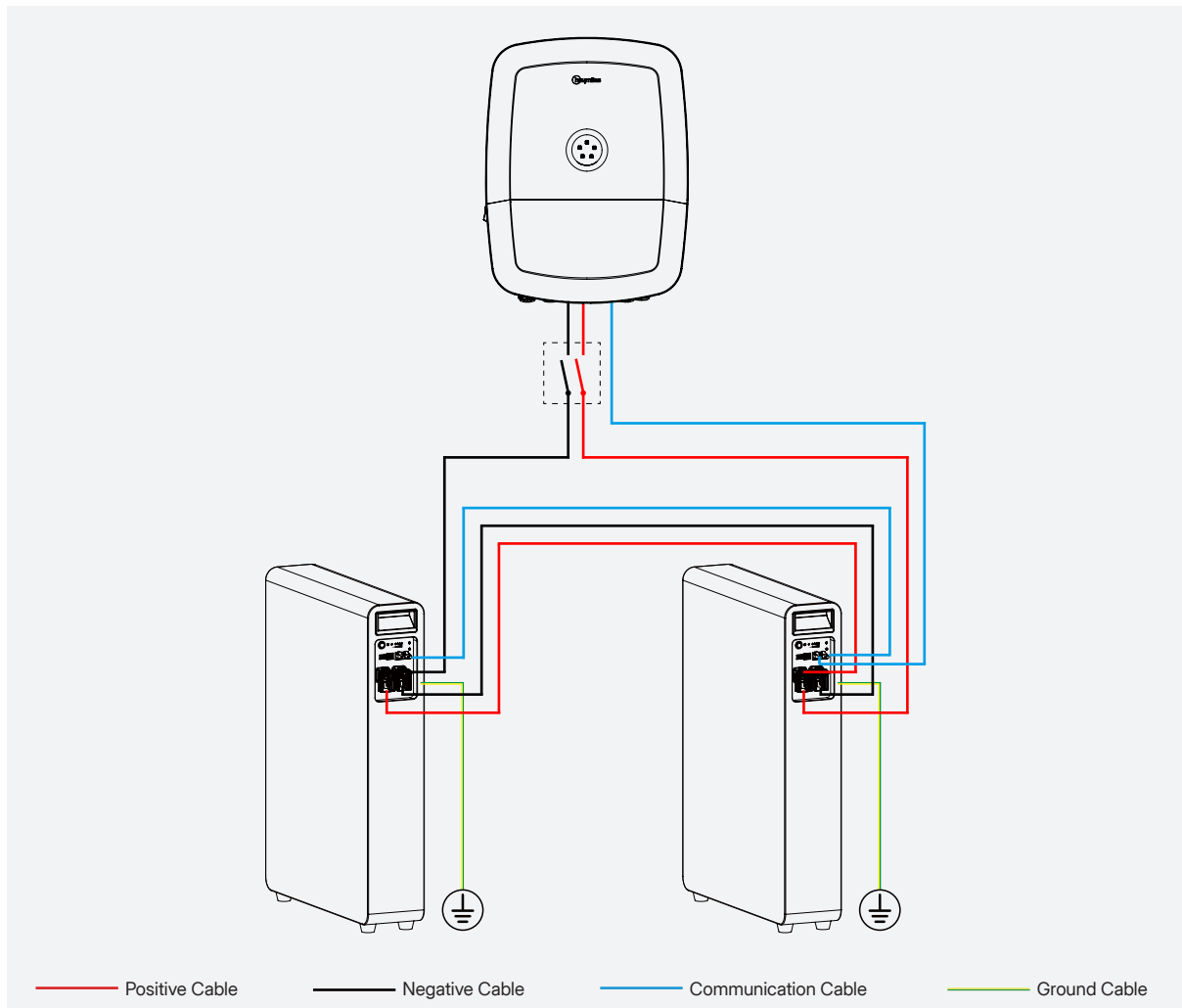

#### **NOTE**

- When two batteries are connected in parallel, they can be connected without a busbar, and the maximum charging or discharging current of the battery system is 200 A. If the current exceeds 200 A, it may cause a risk of fire.
- When two batteries are connected in parallel, this is the only solution.
- Insert the provided 120  $\Omega$  RJ45 connector into the unused communication terminal.

**Parallel Connection with Busbar (3≤Number of Batteries≤15)**

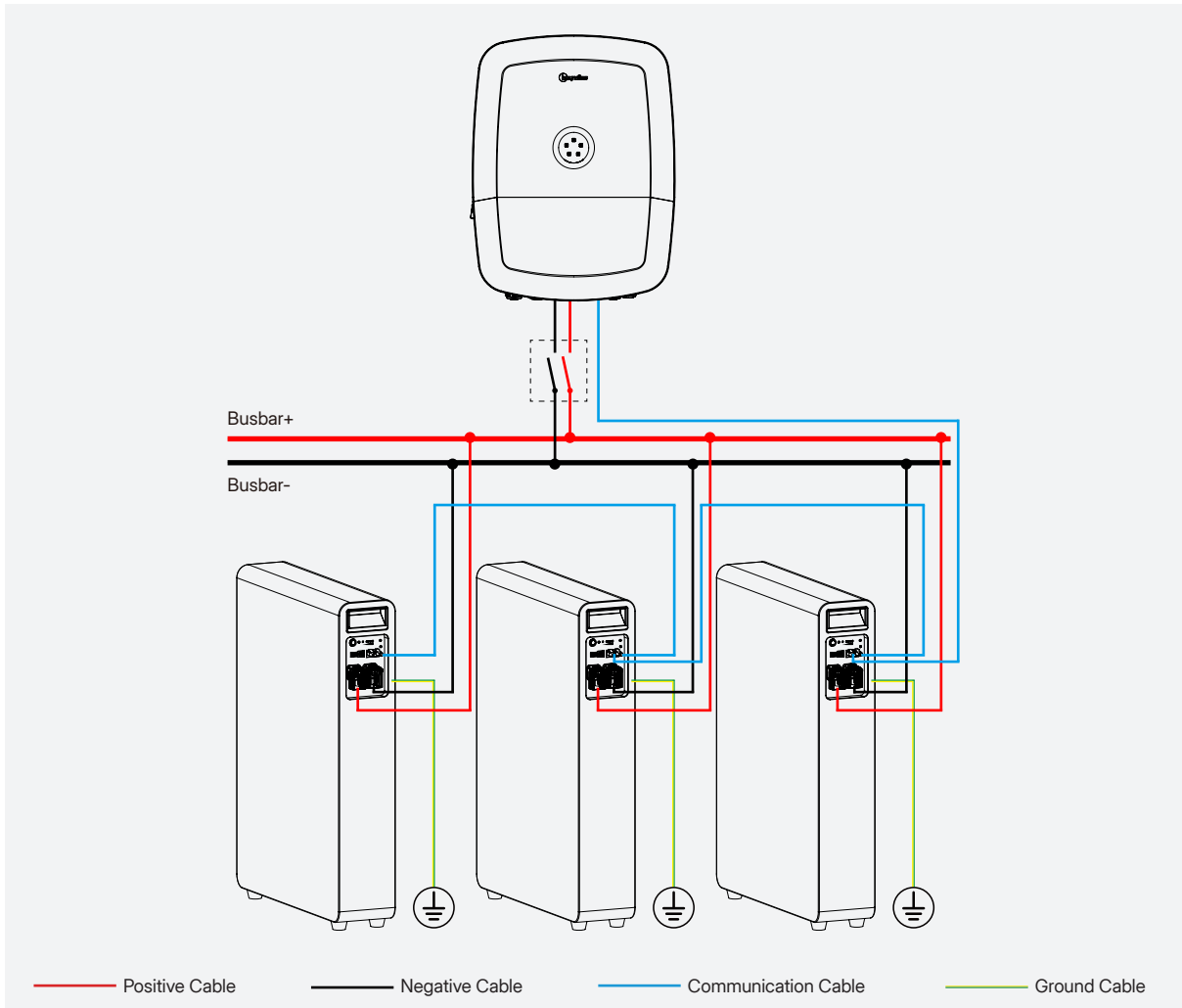

**NOTE**

- When three or more batteries are connected in parallel, they must be connected through a busbar, and the maximum charging or discharging current of the battery system is 400 A.
- Insert the provided 120 Ω RJ45 connector into the unused communication terminal.

## 6 Installation Instructions

### **⚠ DANGER**

#### **Danger to life due to fire or explosion!**

- Despite careful construction, electrical devices can cause fires. This can result in death or serious injury.
- Do not mount the product in places containing highly flammable materials or gases.
- Do not mount the product in places where there is a risk of explosion.

### 6.1 Unpacking

Unpack the package and carefully take out the product and other accessories. Check that the deliverables are complete and intact. Please contact your supplier if the components are missing or damaged upon receipt of the battery.

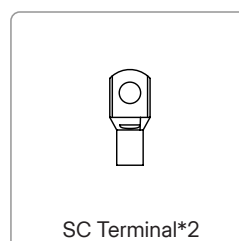
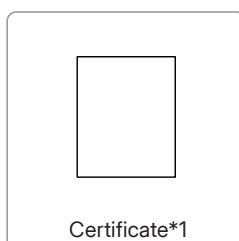
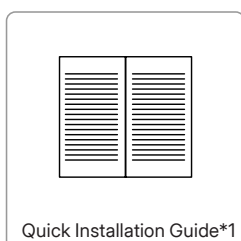
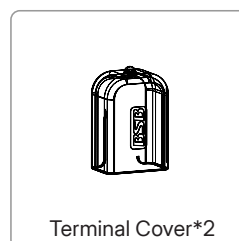
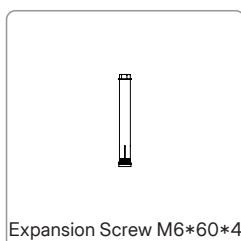
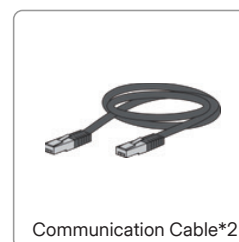
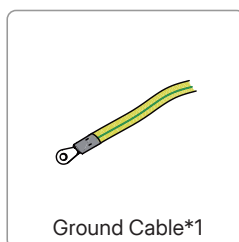
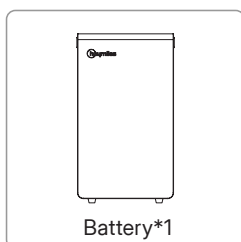

### **NOTE**

- The communication cables are available in two lengths (1 m and 1.5 m). The 1 m cable is for parallel connection, and the 1.5 m cable is used to connect to the inverter.
- The two SC terminals are for parallel connection.

### 6.2 Environmental Requirements

- The equipment should be installed on a solid surface such as concrete or masonry.
- The installation location must be inaccessible to children.
- The installation location must be suitable for the weight and dimensions of the battery.
- The equipment should be protected from conductive (metal) dust.
- The circuit breaker of the BESS must always be freely accessible.
- The recommended ambient temperature is between 15°C and 35°C.
- The operating temperature should be between -20°C and 50°C.
- The relative humidity should be between 10% and 95%.
- The altitude should be no more than 2000 m.











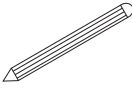
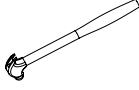
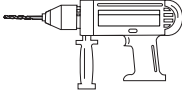
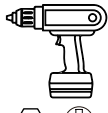

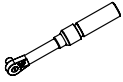
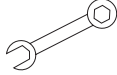

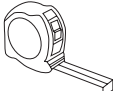
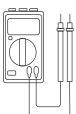
- The product should be installed in an environment with good ventilation and heat dissipation conditions.
- The product should be installed indoors and should meet the following requirements, including but not limited to:
  - a) Keep distance from doors, windows, or other batteries.
  - b) Keep away from the heating device.
  - c) Keep away from corrosive chemicals.

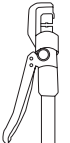
### 6.3 Space Requirements

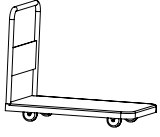

### 6.4 Installation Tools

The following tools are recommended in the installation process, and other auxiliary tools can also be used on site if necessary.

 Detector	 Marker	 Hammer	 Hammer Drill	 Electric Screwdriver
 Screwdriver	 Torque Wrench	 Adjustable Wrench	 Level	 Tape Measure
 Multimeter	 Wire Stripper	 Hydraulic Pliers	 Insulating Tape	 Dolly
<b>Personal Protective Equipment (PPE)</b>				
 Safety Helmet	 Protective Goggles	 Dust Mask	 Safety Gloves	 Safety Shoes

## 6.5 Installation Steps

### Step 1 Marking the Hole Position

- a. Select a load bearing wall constructed with reinforced concrete and use a detector to detect whether there are cables or water tubes behind it.
- b. Horizontally mark the hole position.

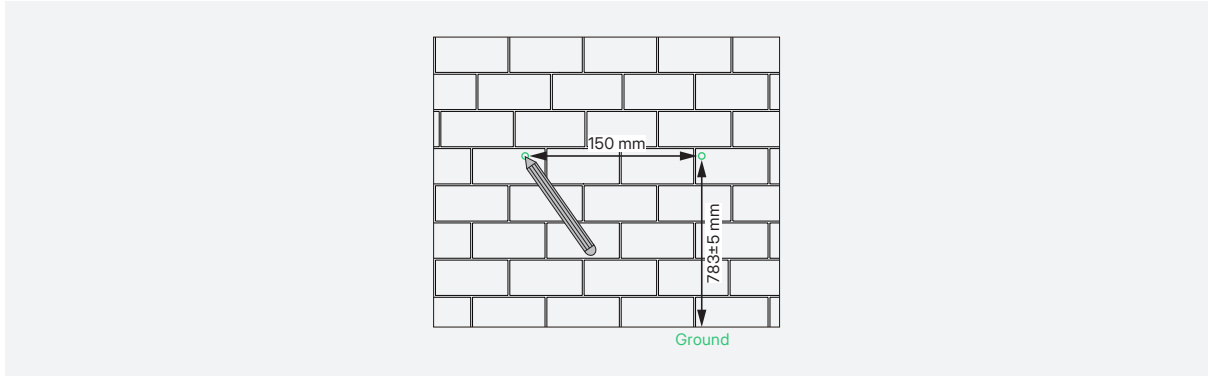

### Step 2 Drilling Holes

Use a hammer drill to drill holes with a diameter of 8 mm and a depth of 50 mm.

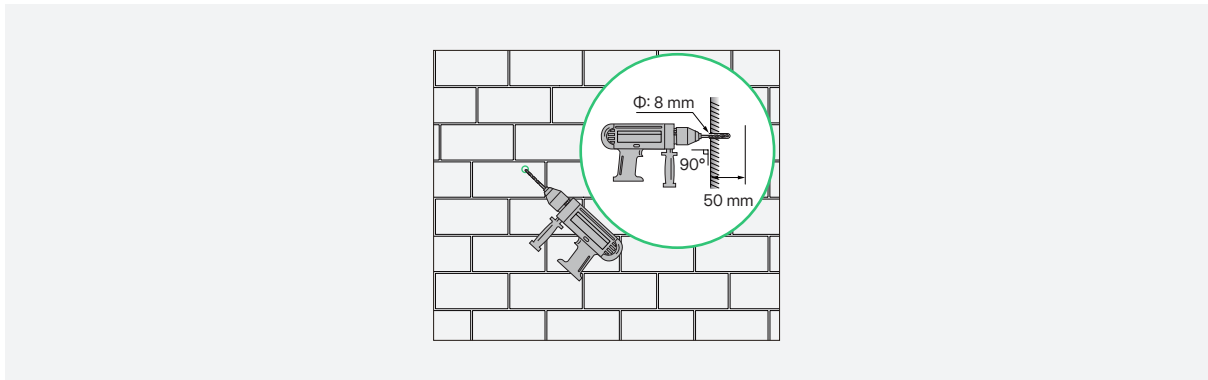

### Step 3 Installing Expansion Screws

- a. Hammer the M6\*32 sleeves into the hole.
- b. Tighten the M6\*60 screws with a torque of 8 N·m and leave a certain length to secure the battery.

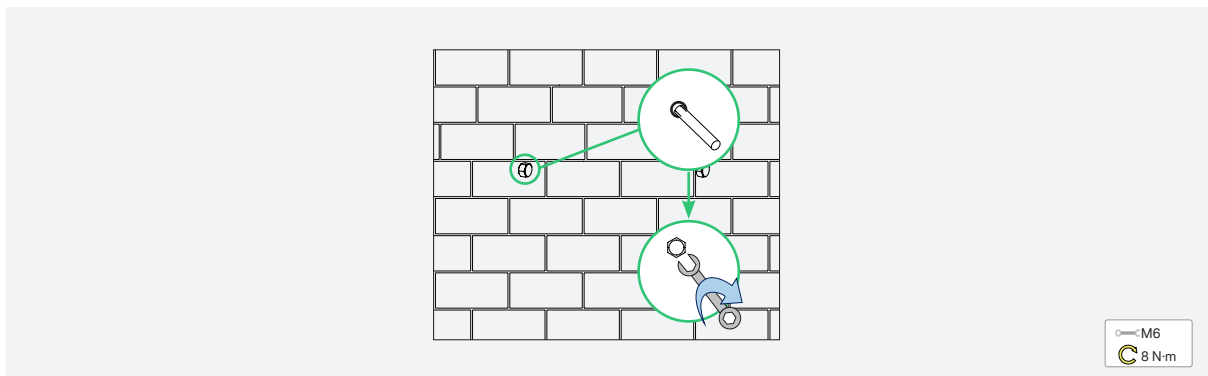

**Step 4 Placing the Battery**

Place the battery on a level ground ( $0^{\circ}$ - $3^{\circ}$ ), parallel to the wall, and keep a distance of at least 10 mm.

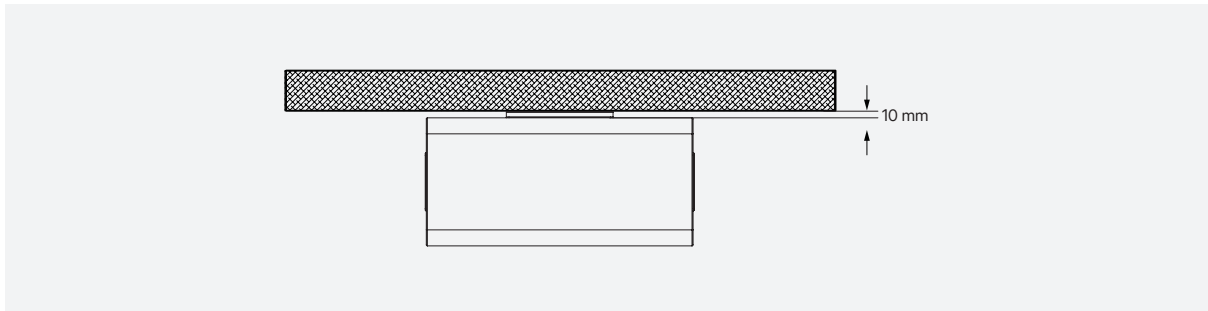
**Step 5 Fixing the Battery**

Hang the battery on the expansion screws through the screw holes of the mounting bracket to fix the battery against the wall.

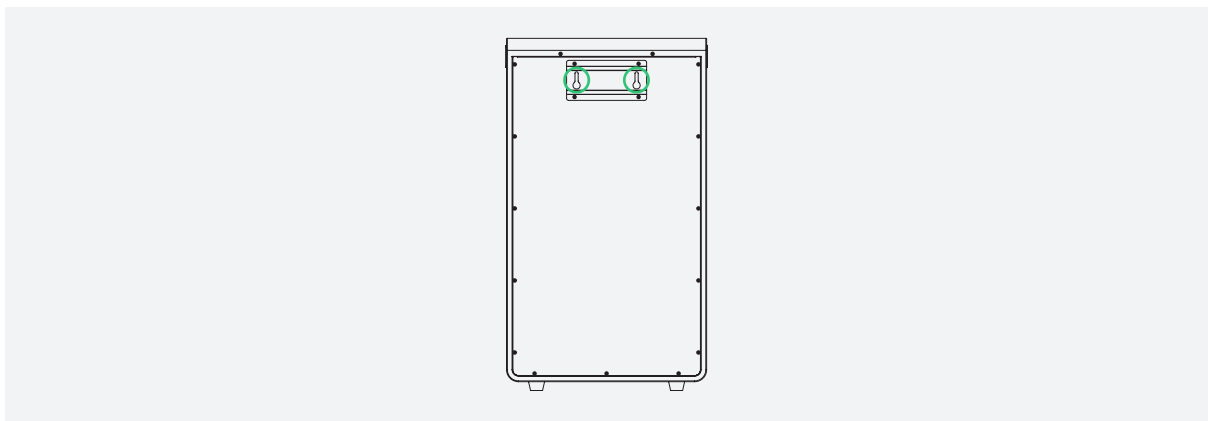

# 7 Electrical Connection

**NOTICE**

- Before the electrical connection, disconnect all power suppliers, and ensure that the circuit breaker and all switches connected to the energy storage system are in the OFF state. Otherwise, an electric shock may occur.
- It is recommended that a circuit breaker between the inverter and the battery be installed in accordance with local laws and regulations.

Cable (90°C, Copper)	Recommended Specification (mm <sup>2</sup> )
Ground Cable	4 mm <sup>2</sup> (12 AWG)
Positive Cable	50 mm <sup>2</sup> (1/0 AWG)
Negative Cable	50 mm <sup>2</sup> (1/0 AWG)
Communication Cable	Standard Ethernet cable

**NOTE**

- The communication cables are available in two lengths (1 m and 1.5 m).
- The 1 m cable is for parallel connection.
- The 1.5 m cable is used to connect to the inverter. Pay attention to the different marks (PACK and INV) on the two ends to correctly connect the battery and the inverter.

## 7.1 Single battery System

### 7.1.1 Ground Cable Connection

**Step 1** Connect the ground cable to the ground terminal.

**Step 2** Tighten the M5 screw with a torque of 4 N·m.

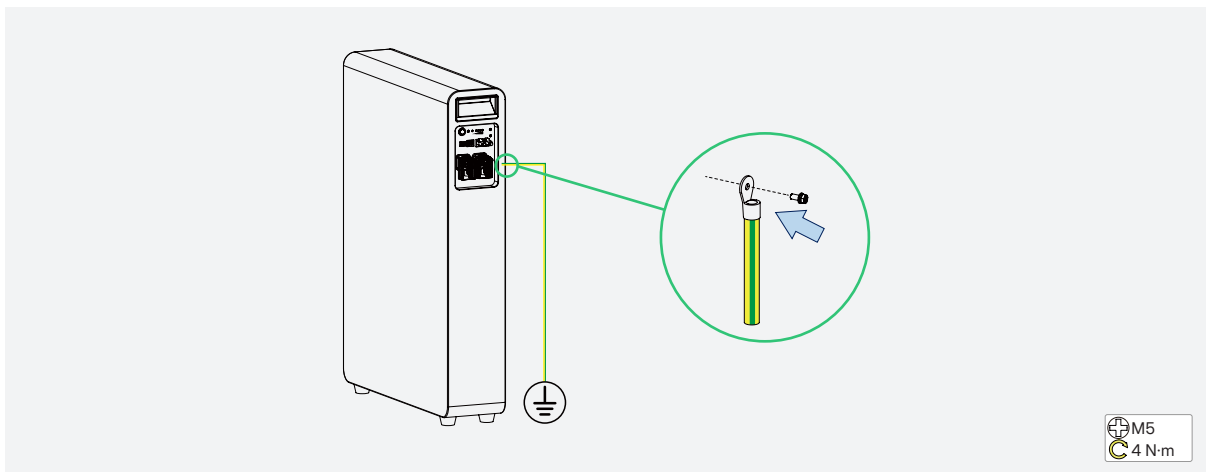

## 7.1.2 Power Cable Connection

**Step 1** Connect the power cables to the Output + and Output - terminals.

**Step 2** Tighten the M8 screws with a torque of 8 N·m.

**Step 3** Install the two terminal covers.

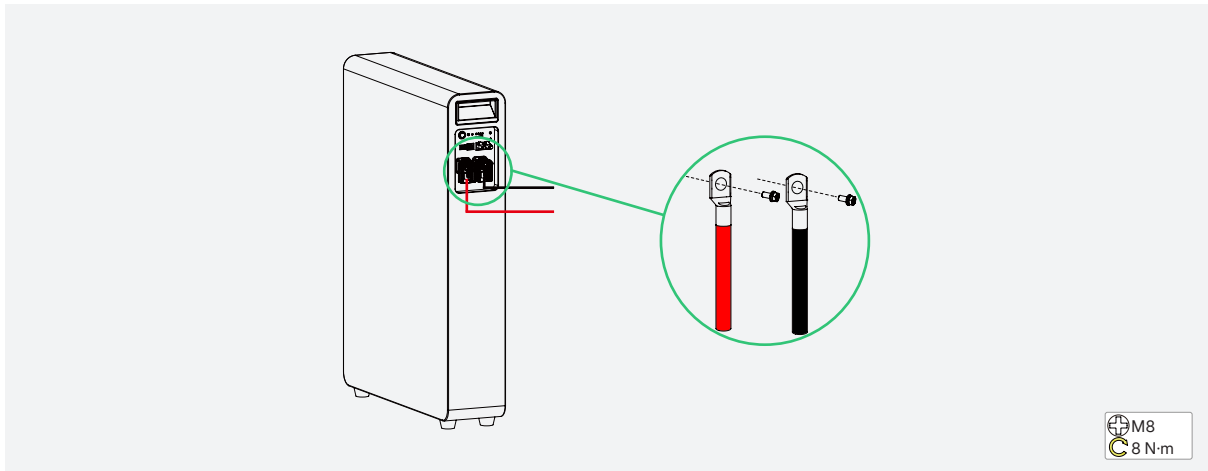

## 7.1.3 Communication Cable Connection

**Step 1** Connect the communication cable to the communication terminal (CAN).

**Step 2** Insert the provided 120  $\Omega$  RJ45 connector into the unused communication terminal.

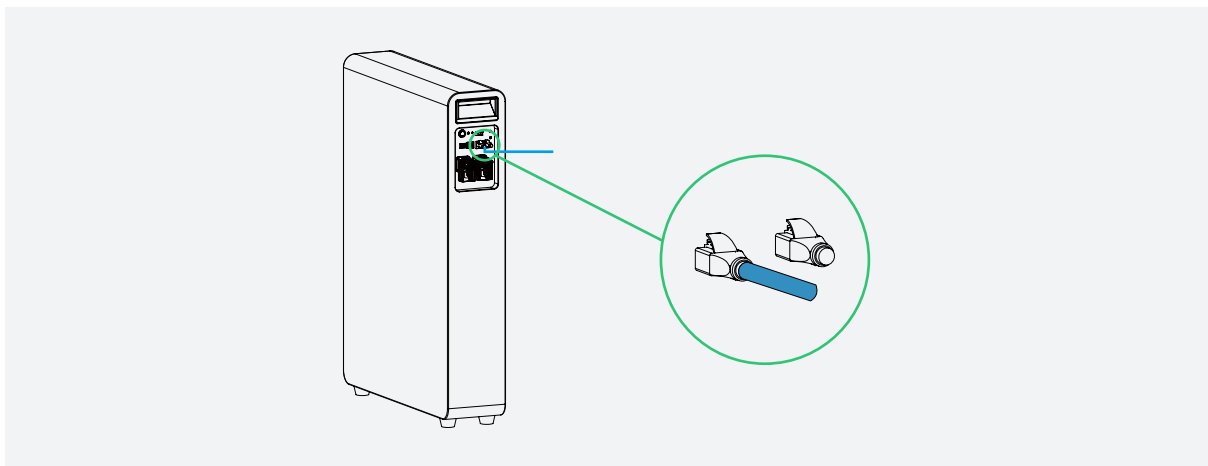

## 7.2 Multi-battery System

### 7.2.1 Ground Cable Connection

Connect ground cables as described in [7.1.1 Ground Cable Connection](#).

### 7.2.2 Power Cable Connection

#### Parallel Connection Without Busbar (Number of Batteries=2)

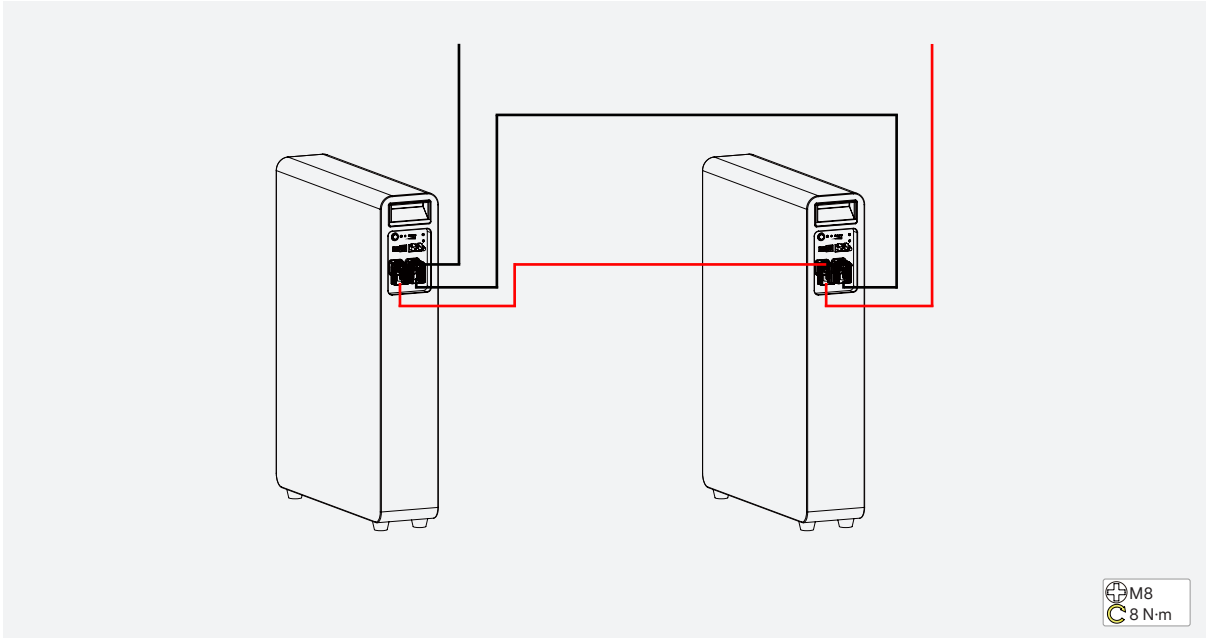

#### Parallel Connection with Busbar ( $3 \leq$ Number of Batteries $\leq 15$ )

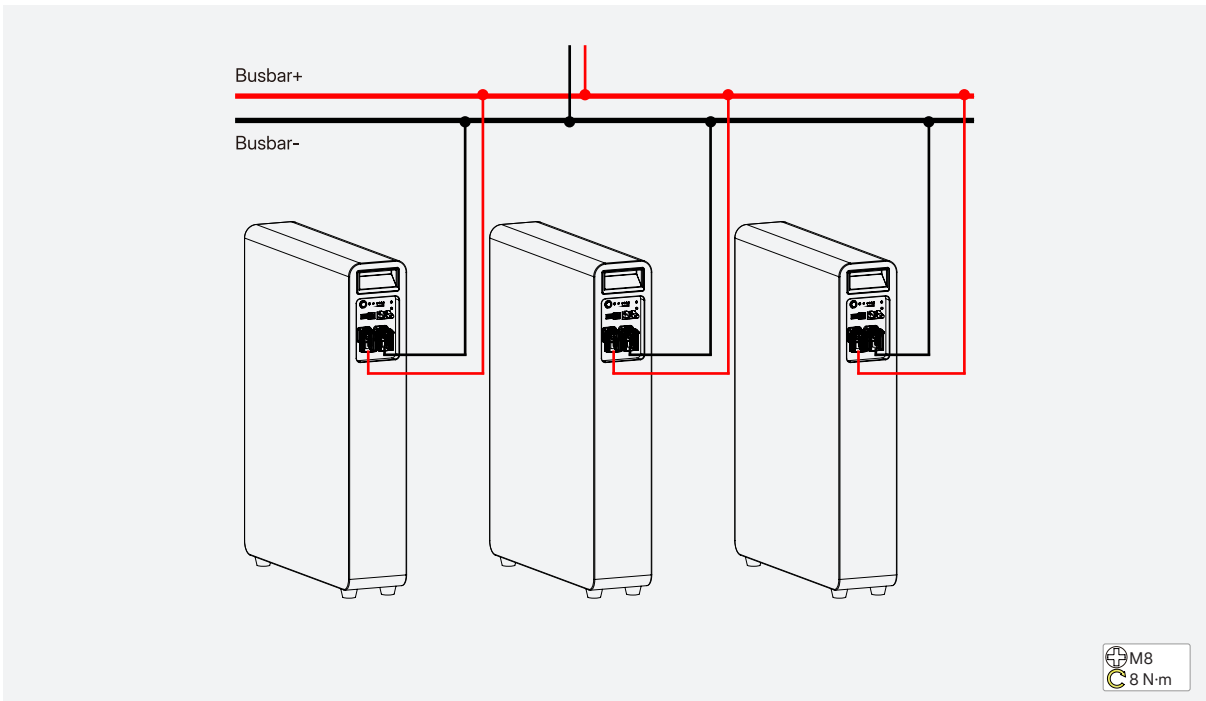

### 7.2.3 Communication Cable Connection

#### Parallel Connection Without Busbar (Number of Batteries=2)

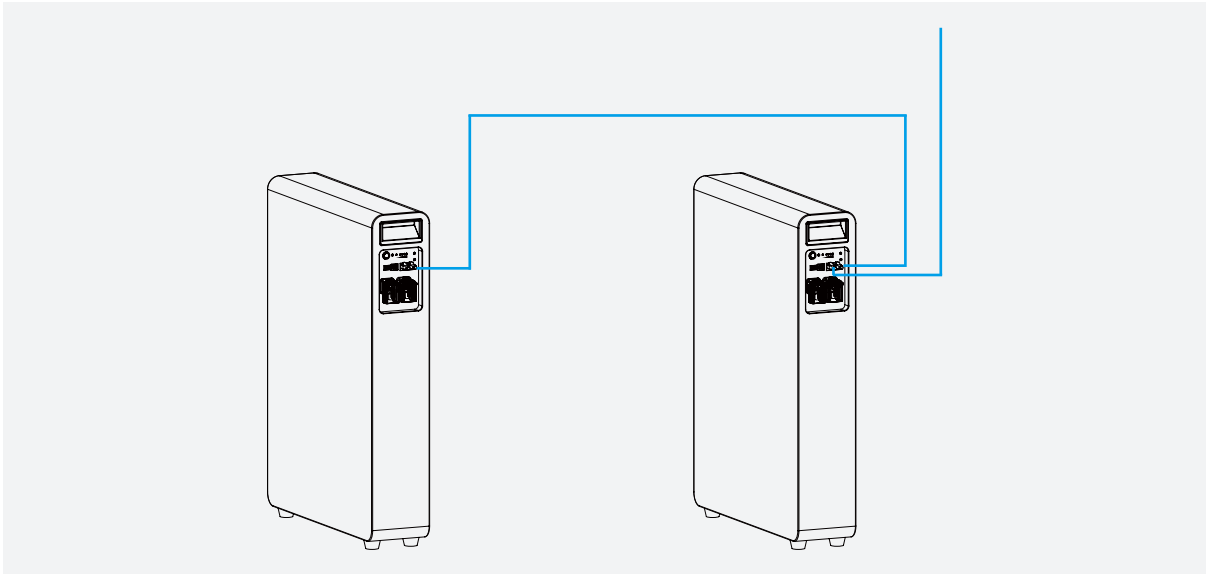

#### Parallel Connection with Busbar (3 ≤ Number of Batteries ≤ 15)

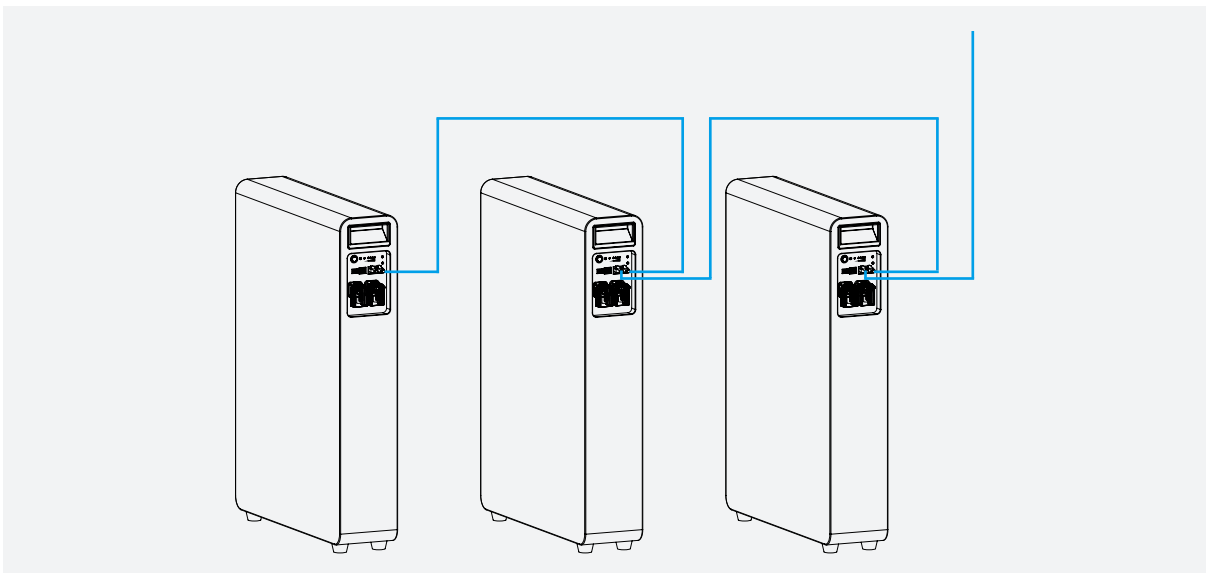

**NOTE**

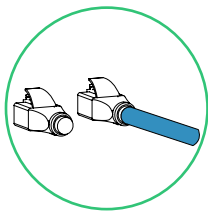

Insert the provided 120 Ω RJ45 connector into the unused communication terminal.

## 8 System Commissioning

### 8.1 Preparation

Before the commissioning of the product, make sure:

- The power switch and external circuit breaker are disconnected.
- Check wiring according to [7 Electrical Connection](#).
- Unused terminals must be sealed using corresponding sealing plugs.
- Nothing is left on the top of the inverter and battery.
- Cables are routed in a safe place or protected against mechanical damage.
- Warning signs and labels are intact.

### 8.2 System Power-on

#### NOTICE

Ensure that all cables are connected correctly and firmly.

**Step 1** Turn on the circuit breaker between the battery and the inverter.

**Step 2** Press the power switch for 1s. Wait until the LED indicators are on and there is no alarm sound, which means the battery works normally.

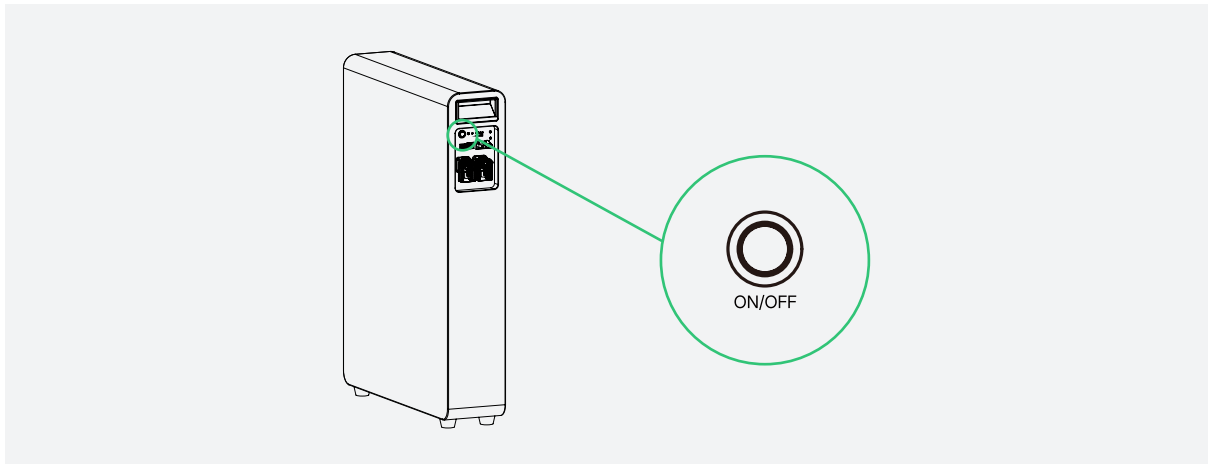

#### NOTE

The DIP switch is used for a parallel system. When the battery communicates with the inverter via CAN, adjust the DIP switch to set the BMS address. Set the BMS address of the master battery to 0, and set the BMS address of the slave batteries to 1 - 15 in sequence.

For DIP switch instructions, refer to [4.3 DIP Switch Instructions](#).

## 9 System Maintenance

### 9.1 System Power-off

**Step 1** Turn off the circuit breaker between the battery and the inverter.

**Step 2** Turn off the power switch.

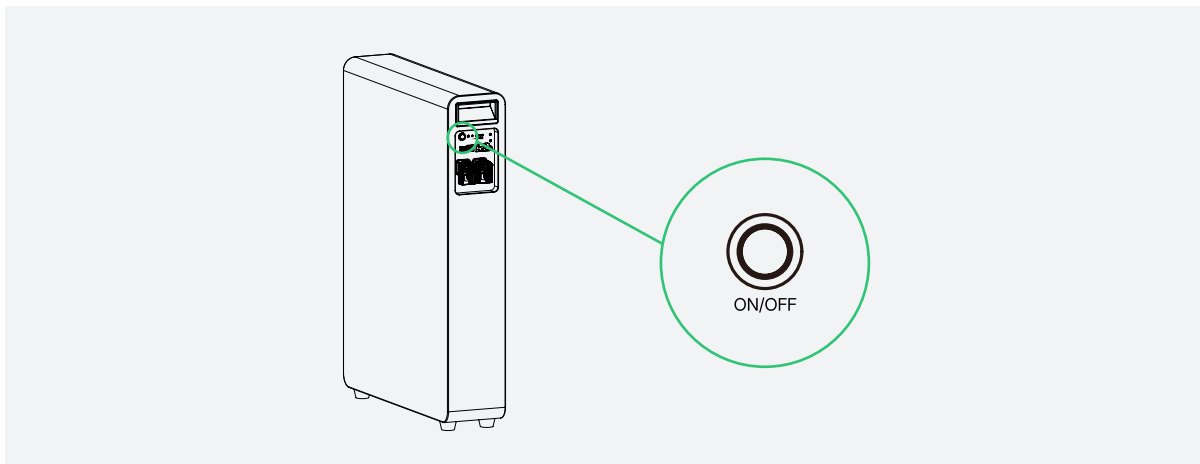

### 9.2 Routine Maintenance

To ensure that the battery can operate for a long time, it is recommended to perform the following maintenance items. Make sure that all maintenance items are performed after the battery is powered off.

Check Item	Check Method	Maintenance Interval
System Cleanliness	<ul style="list-style-type: none"> <li>Periodically check whether the battery is damaged or deformed.</li> <li>Clean the system.</li> </ul>	Once every 6 to 12 months
System Operation Status	<ul style="list-style-type: none"> <li>Check whether there is an abnormal sound during operation.</li> <li>Check whether the indicator works normally.</li> <li>Check whether the system parameters are set correctly.</li> <li>Update the software.</li> </ul>	Once every 6 months
Electrical Connection	<ul style="list-style-type: none"> <li>Check whether the cables are firmly connected and intact; in particular, ensure that the parts being contacted with the metal surface are not scratched.</li> <li>Check whether the cable is discolored.</li> </ul>	The first inspection is 6 months after the initial commissioning, and the subsequent inspections can be carried out once every 6 to 12 months.
Grounding Reliability	Check whether the ground cables are firmly connected.	The first inspection is 6 months after the initial commissioning, and the subsequent inspections can be carried out once every 6 to 12 months.

### 9.3 Troubleshooting

Fault	Possible Causes	Handling Suggestions
The LED indicators do not light	The power cable of the battery is not properly connected.	Reconnect the power cable of the battery.
	The power switch is off.	Turn on the power switch.
	The BMS is in a sleep state.	Charge the battery.
	The BMS is damaged.	Please contact Hoymiles technical support team.
Unable to discharge	The terminals of the battery are damaged.	Replace the battery wiring terminals.
	BMS communication failure.	Reconnect the communication cable between the BMS and the battery. If the communication cable is damaged, replace it.
	The power switch is off.	Turn on the power switch.
Unable to charge	The terminals of the battery are damaged.	Replace the battery wiring terminals.
	BMS communication failure.	Reconnect the communication cable between the BMS and the battery. If the communication cable is damaged, replace it.
	The power switch is off.	Turn on the power switch.
Communication fails	The power switch is off.	Turn on the power switch.
	The BMS is in a sleep status.	Charge the battery.
	The communication cable is damage.	Replace the communication cable.
Inaccurate voltage display	The voltage sampling cable is damaged.	Replace the voltage sampling cable.
	The BMS is damaged.	Please contact Hoymiles technical support team.
Low capacity	The battery has not been maintained for a long time.	Use an equalizer to maintain the battery.
	The single battery is damaged.	Replace the damaged single battery.
	Inaccurate voltage sampling.	Please contact Hoymiles technical support team.
Low cell voltage	The battery has not been maintained for a long time.	Use an equalizer to maintain the battery.
	The single battery is damaged.	Replace the damaged single battery.
	Inaccurate voltage sampling.	Please contact Hoymiles technical support team.

## 10 Decommissioning

### 10.1 Removing the Product

**Step 1** Power off the product as described in [9.1 System Power-off](#).

**Step 2** Disconnect all cables.

**Step 3** Remove the product from the wall.

### 10.2 Packing the Product

If the original package is available, put the product and its accessories into the package and keep it in a dry and proper place.

If the original package is not available, put the product and its accessories into a suitable package. The package should be easy to remove, can bear the weight of the product, and can be sealed properly.

### 10.3 Disposing of the Product

Disposal of the system must comply with applicable local regulations for the disposal of electronic waste and used batteries.

- Do not dispose of the battery system with your household waste.
- Avoid exposing the battery to high temperatures or direct sunlight.
- Avoid exposing batteries to high humidity or corrosive environments.

For more information, please contact the original manufacturer.

# 11 Handling Precautions and Guidelines for Product

These Handling Precautions and Guidelines for Rechargeable Battery System (“Handling Precautions and Guidelines”) shall only apply to the packs manufactured by Hoymiles. Customers shall strictly follow these Handling Precautions and Guidelines, and shall alert its customers, contract manufacturers, agents, distributors, service providers, and end-users of the risks of the packs. Customers should also ensure that they observe their obligations as specified in the document and the handling precautions and guidelines. Detailed information is available on the printed label of the product, a quick installation guide, a help file, or an official website. The entire chain including customers, distributors, and end-users should be committed to these obligations so that the product can be properly handled, transported, installed, operated, and maintained.

## Statement (1):

Customers are requested to contact Hoymiles in advance, if and when customers need other applications or operating conditions other than those described in this document. Additional experimentation may be required to verify performance and safety under such conditions.

## Statement (2):

Hoymiles will take no responsibility for any accidents in the event the product is used for applications or under conditions other than those described in this document.

- Use the product under specified charge/discharge conditions.
- Do not immerse the product in water.
- Do not heat the product.
- Do not attempt to crush, drop, or penetrate the product.
- Do not attempt to have any modifications.
- Leave the product in cool places.
- Stop using the product with any color change or mechanical damage detected during assembly, charging, normal operation, and storage.
- In case of leakage or smells, track to the thermal source, remove the thermal source, and clean it with water.
- Do not place or leave the pack and equipment in the reach of the children.
- Keep leaked electrolytes away from the eyes or skin. In case of leakage contact with eyes or skin, immediately clean with water and seek help from a doctor. Serious damages can be caused due to delayed treatment.
- Do not put the pack into a fire. Do not use it or leave it in a place near fire, heaters, or high-temperature sources. The heat can melt the pack insulator and damage the safety vent, resulting in overheating, explosion, or fire of the pack.
- Do not submerge the product in water or wet the product. If the protective devices are damaged, abnormal charging current and voltage may cause a chemical reaction within the product, which may result in overheating, explosion, or fire of the pack.
- Do not reversely connect the positive (+) and negative (-) terminals of the product.
- Do not contact the product terminals (+ and -) directly with a wire or any metal (like a metal necklace or a hairpin). Otherwise, the product will be short-circuited and generate excessive current, which may result in the overheating, explosion, or fire of the pack.
- Do not throw or drop the pack. Strong impact may damage the protective devices, and an abnormal chemical reaction might occur during charge, resulting in overheating, explosion, or fire of the pack.
- Do not drive a nail in, hit with a hammer, or stamp on the pack. Otherwise, the pack may be deformed and short-circuited, resulting in overheating, explosion, or fire of the pack.
- Do not solder the pack directly. Heat applied during soldering may damage the insulator of the safety vent and mechanism, resulting in overheating, explosion, or fire of the pack.
- Do not disassemble or alter the pack. The pack employs a safety mechanism and a protection device to avoid any danger. If they are damaged, the pack might overheat, explode, or catch fire.
- Do not put the pack in a microwave oven or a pressure cooker. Sudden heat may damage the sealing of the pack and may cause overheating, explosion, or fire of the pack.

- Do not leave the pack in a charger or equipment if it generates an odour and/or heat, changes color and/or shape, leaks electrolytes, or encounters any other abnormality. In such a case, immediately take the pack out of the charger or equipment and keep it away from fire. Otherwise, the pack might overheat, explode, or catch fire.
- Stop charging or using the battery after the battery reaches its lifetime; otherwise, the battery might cause overheating, explosion, or fire.
- Do not use the pack beyond specified conditions. Otherwise, the pack might encounter overheating, damage, or performance deterioration.
- Read the instructions regarding the installation and operation to avoid damages due to incorrect operations.
- The battery may have insufficient power capacity after long storage.
- Knockoff or counterfeit battery.
- Any inconsistency among serial number, model number, and product code.

## 12 Technical Datasheet

Model	LB-16D-G2
<b>System Data</b>	
Battery type	LiFePO <sub>4</sub>
Rated capacity (Ah)	314
Total energy (kWh)	16.08
Rated voltage (V)	51.2
Voltage range (V)	42-57.6
Rated charging/discharging current (A)	62.8/157
Max. continuous charging/discharging current (25°C) (A)	157
Peak charging/discharging current (A)	200 (10s)
Max. charging/discharging power (kW)	8.04
Communication	CAN
Recommended depth of discharge (DOD)	90%
Max. parallel quantity	15
<b>Protection</b>	
Overvoltage and undervoltage protection	Integrated
Overcurrent protection	Integrated
Overtemperature and undertemperature protection	Integrated
<b>General</b>	
Dimensions (W × H × D [mm]) <sup>(1)</sup>	500 × 880 × 240
Weight (kg) <sup>(1)</sup>	115
Installation Environment	Indoor
Mounting	Floor standing
Charging temperature (°C)	0 to +55
Discharging temperature (°C)	-20 to +55
Protection degree	IP20
Cooling	Natural convection
Altitude (m)	≤2000
Cycle life (25°C)	6000 Cycles
Certification	IEC 62619, UN 38.3, CE-EMC, CB
Warranty <sup>(2)</sup>	5-10 Years

(1) The actual dimensions and weight may differ. For details, please contact Hoymiles sales.

(2) Please refer to Hoymiles Warranty Terms & Conditions for more details.



## Hoymiles Power Electronics Inc.

 Floor 6, Building 5, 99 Housheng Road,  
Gongshu District, Hangzhou 310015 P. R. China

 +86 571 2805 6101

 [hoymiles.com](http://hoymiles.com)

 [service@hoymiles.com](mailto:service@hoymiles.com)  
[support@hoymiles.com](mailto:support@hoymiles.com)

