

Low Voltage Battery

Quick Installation Guide



LB-16D-G3

Contents

1	General Declaration	1
2	Packing List.....	1
3	Appearance and Dimensions.....	2
4	Pre-Installation.....	3
5	Mechanical Installation	4
	5.1 Floor Standing.....	4
	5.2 (Optional) Wall Mounting.....	6
	5.3 (Optional) Wheel Mounting	7
6	Electrical Connection	8
	6.1 Copper Busbar Specifications.....	8
	6.2 Single-Inverter System	9
	6.2.1 Single-Battery System.....	9
	6.2.2 Multi-Battery System.....	10
	6.3 Multi-Inverter System.....	11
7	System Commissioning.....	12
	7.1 System Power-On	12
	7.2 LED Indicators	13
	7.3 (If Needed) System Power-Off.....	13















1 General Declaration

- This quick installation guide is subject to change due to product updates or other reasons.
- Read this quick installation guide carefully before installation to learn about product features and safety precautions.
- Only qualified personnel are allowed to install, operate, and maintain the equipment.
- Installers should be familiar with local laws and regulations.
- Check the deliverables for correct model, complete contents, and intact appearance. Contact the manufacturer if any damage is found or any component is missing.
- Installers must use insulated tools and wear personal protective equipment.
- As required by local regulations, an overcurrent protection and isolation device should be installed between the inverter and the battery. The cable needs to be prepared by the installer.
- Before installation, ensure that the battery is turned off, and any associated circuit breakers and disconnect switches are turned off.

	Do not dispose of the device as household waste.		Observe the documentation.
	Hoymiles Power Electronics Inc. hereby declares that Hoymiles Battery (model: LB-16D-G3) is in compliance with the essential requirements and other relevant provisions of directives 2014/30/EU, 2011/65/EU, (EU)2015/863, and EU Battery Regulation (EU)2023/1542. The original EU Declaration of Conformity may be found at https://www.hoymiles.com/ .		

2 Packing List



Standard

 <p>Battery*1</p>	 <p>Handle*4</p>	 <p>Bracket A*2</p>	 <p>Levelling Feet*4</p>	 <p>Positioning Board*1</p>
 <p>Expansion Screw M8*80*2</p>	 <p>Screw M8*16*2</p>	 <p>Screw M5*14*4</p>	 <p>Screw M4*10*1</p>	 <p>Ground Cable*1 (1m, 6 mm² / 10 AWG)</p>
 <p>Power Cable*2 (1.5 m, 1 AWG)</p>	 <p>Communication Cable*2</p>	 <p>Waterproof RJ45 Connector*2</p>	 <p>Installation Guide*1</p>	 <p>Certificate*1</p>

Note:

- The communication cables are available in two lengths. The 1 m cable (marked by BAT) is for parallel connection, and the 1.5 m cable (marked by INV) is used to connect to the inverter.

- If you use self-prepared communication cables, reserve only pins 4 (CAN1H) and 5 (CAN1L) of the cable end connected to the inverter. The pin definition is as follows:

Terminal	1	2	3	4	5	6	7	8
 <p>COM IN</p>	485-1A-PCS	485-1B-PCS	485-2A-IN	CAN1H	CAN1L	485-2B-IN	DI	GND1
 <p>COM OUT</p>	NC	NC	485-2A-IN	NC	NC	485-2B-IN	DO	GND2

Optional

For wall-mounting:

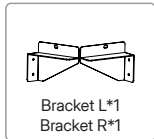

For wheel-mounting:

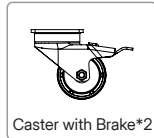

3 Appearance and Dimensions

Unit: mm

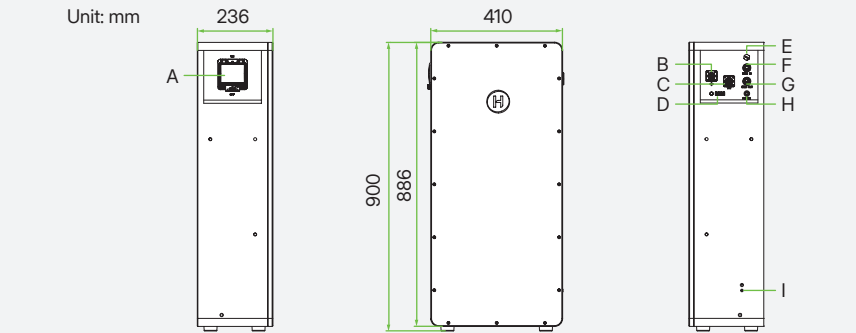

A: DC Circuit Breaker	B: Positive Terminal	C: Negative Terminal	D: LED Indicators
E: Relief Valve	F: COM IN	G: COM OUT	H: Power Button
I: Ground Terminal			

4 Pre-Installation

Environmental Requirements

Category	Requirement
Recommended storage temperature	15 °C to 35 °C
Relative humidity	10% to 95% (non-condensing)
Altitude	≤ 2000 m
Ventilation	Good ventilation and heat dissipation required
Clearance	Keep away from doors, windows, and other batteries
Hazards	Keep away from heat sources, corrosive chemicals, and highly flammable materials or gases.

Clearance Requirements

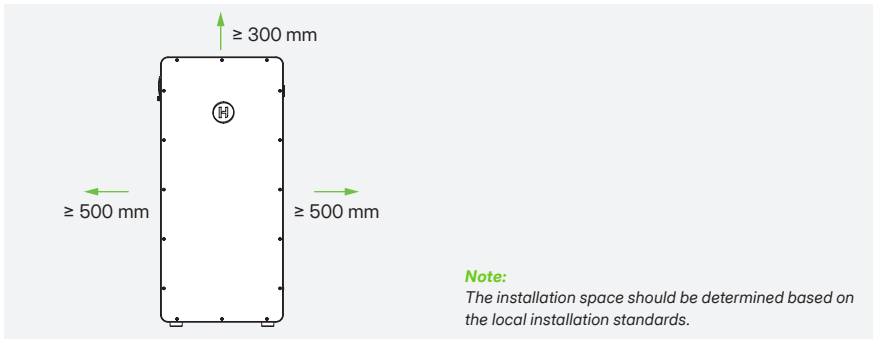

Required Tools and Materials

The following is recommended in the installation process, and other auxiliary tools can also be used if necessary.

Tools

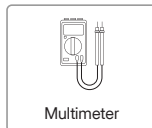
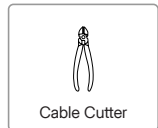
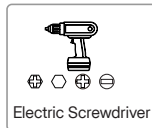
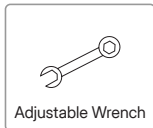
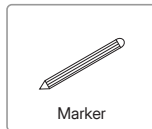
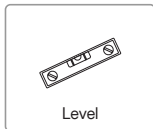

Personal Protective Equipment (PPE)



Handle Installation

Warning: The battery is heavy. Use handles and at least four people to prevent injury!

Before you move the battery, install the handles on the enclosure holes, as shown below.

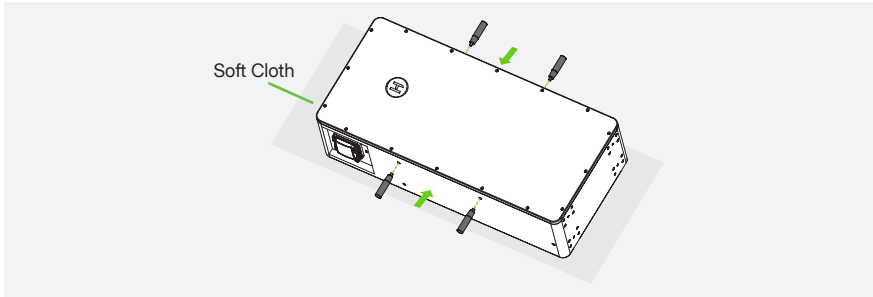

Notice: After positioning the battery, remove the lifting handles and reinstall screws in the handle holes.

5 Mechanical Installation

There are three methods for mechanical installation: floor standing, wall mounting ([page 6](#)), and wheel mounting ([page 7](#)).

5.1 Floor Standing

Step 1: Mark drilling positions.

- Select a load bearing wall constructed with reinforced concrete and use a detector to verify that no electrical wiring or plumbing are present.
- Place the positioning board ("Floor standing" side) on the ground and against the wall. Ensure that the ground is level (0° - 3°).
- Mark drilling positions (marked by "L" and "R").

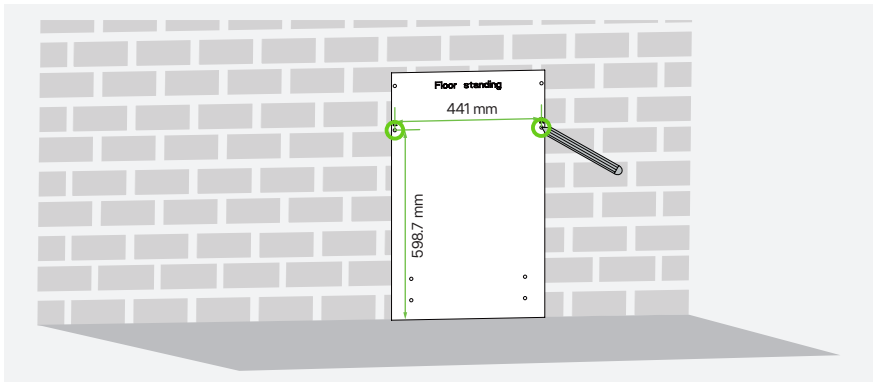

Step 2: Install the expansion sleeves.

- a. Drill holes, each 12 mm in diameter and 65 mm deep.
- b. Hammer the expansion screws into the holes until the washers are flush with the surface.
- c. Fasten each screw clockwise until the sleeve expands and grips the wall firmly.
- d. After the sleeve expands, unscrew and remove the washer and screw.

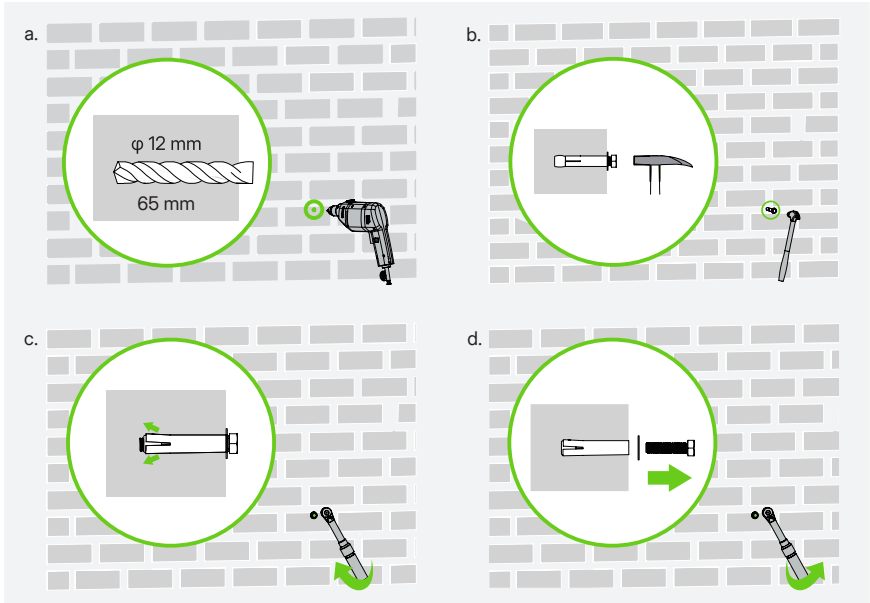

Step 3: Install the levelling feet.

- a. Place a soft cloth on the ground. Hold the handles to slowly lay the battery on the cloth.
- b. Secure the 4 levelling feet.

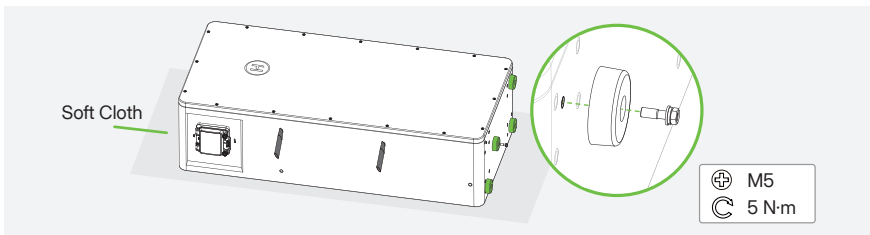

Step 4: Secure the battery to the wall.

- a. Lift the battery up and align it with the wall. Leave 20 mm between the battery and the wall.

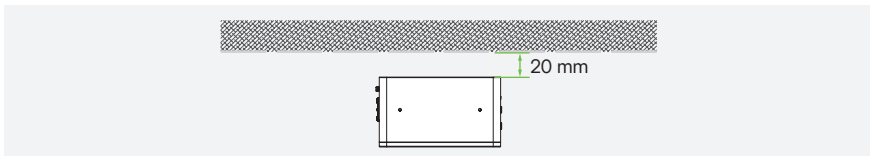

- b. Secure the two bracket A to the battery.
- c. Align the brackets with the installed sleeves and use the expansion screws to secure the brackets to the wall.

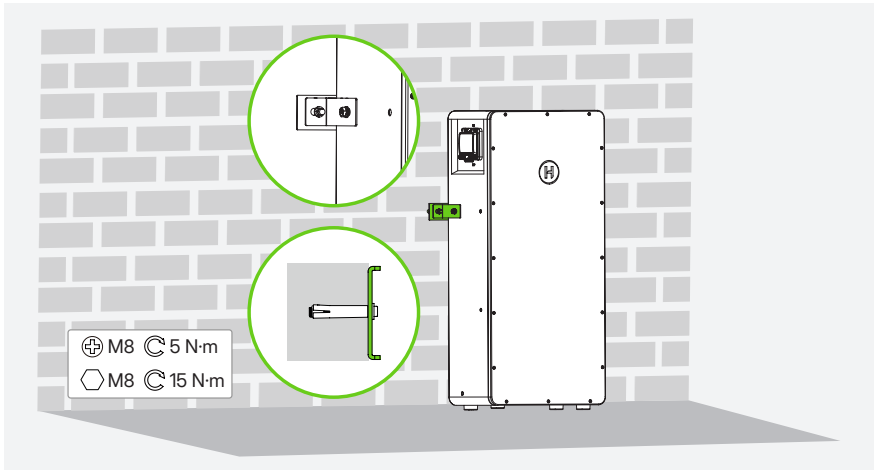

Next: Go to “6 Electrical Connection” on [page 8](#).

5.2 (Optional) Wall Mounting

Step 1: Mark drilling positions.

- a. Select a load bearing wall constructed with reinforced concrete and use a detector to verify that no electrical wiring or plumbing are present.
- b. Place the positioning board (“Wall mounting” side) against the wall and mark drilling positions (marked by “L” and “R”).

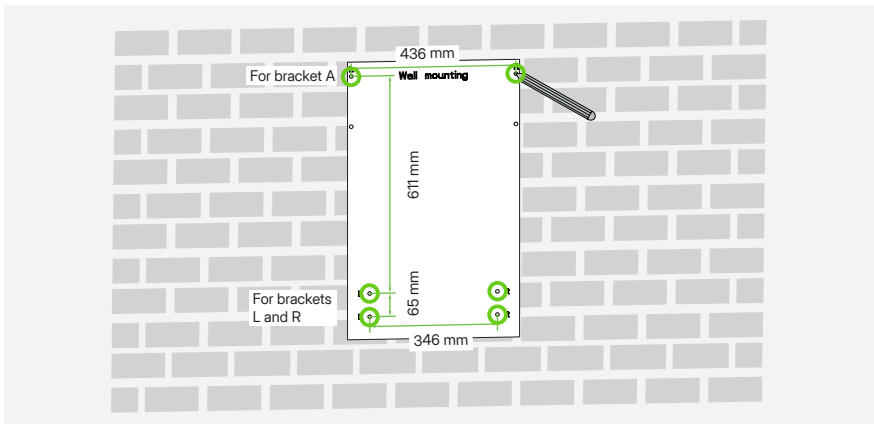

Step 2: Install the expansion sleeves. For details, see the step 2 of “5.1 Floor Standing” on [page 5](#).

Step 3: Align the bracket L and bracket R with the installed sleeves and use the expansion screws to secure the brackets to the wall.

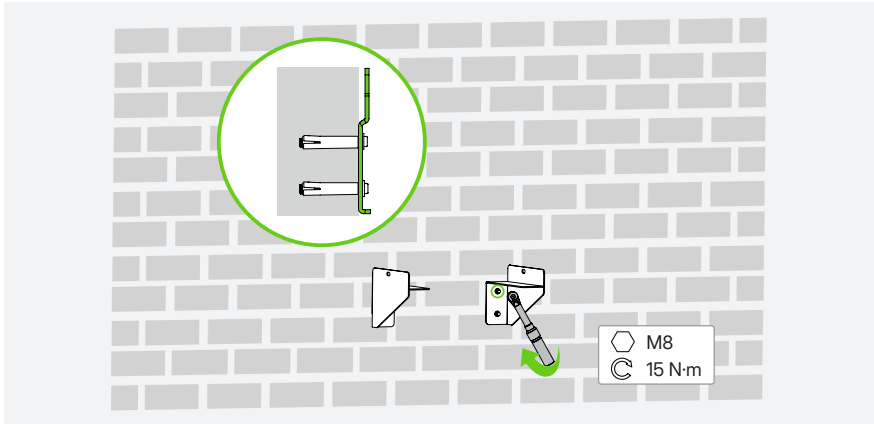

Step 4: Secure the battery to the wall.

Note:

Before you tighten the brackets, ensure that the battery is aligned with the wall.

- Lift the battery via the handles and place it on the bracket L and bracket R.
- Tighten the screws to secure the battery to the bracket L and bracket R.
- Secure the two bracket A to the battery.
- Align the brackets with the installed sleeves and use the expansion screws to secure the brackets to the wall.

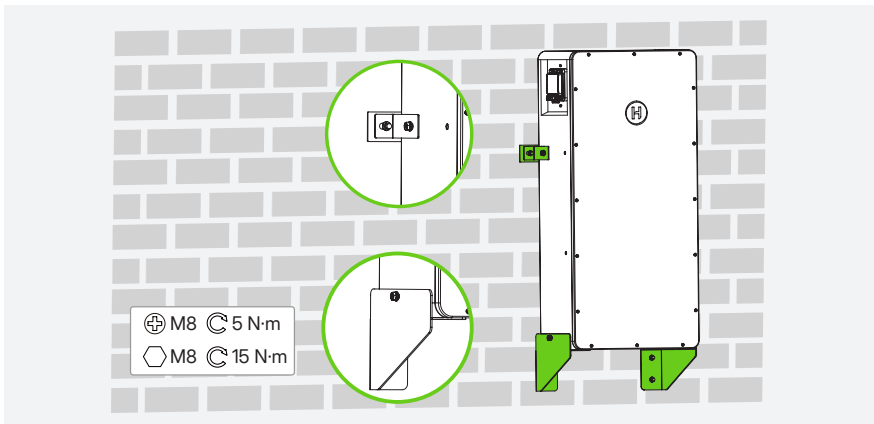

Next: Go to "6 Electrical Connection" on [page 8](#).

5.3 (Optional) Wheel Mounting

Step 1: Mark drilling positions and install the expansion sleeves. For details, see the steps 1 and 2 in "5.1 Floor Standing" on [page 4](#) and [page 5](#).

Step 2: Install the casters.

- a. Place a soft cloth on the ground. Hold the handles to slowly lay the battery on the cloth.
- b. Secure the 4 casters. Install the two casters with brakes at the front side of the battery.

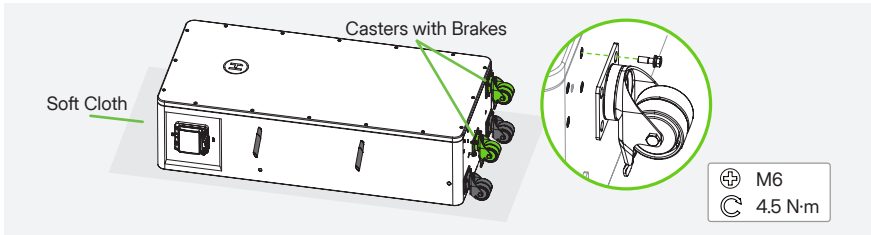

Step 3: Secure the battery to the wall. For details, see the step 4 in “5.1 Floor Standing” on [page 5](#).

Notice:

Push the battery from the sides, not from the front or rear, to prevent it from toppling.

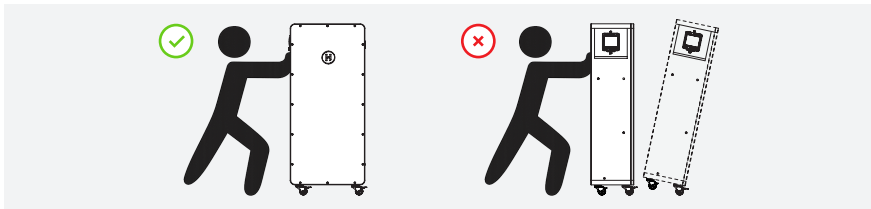

Step 4: Lock the brakes.

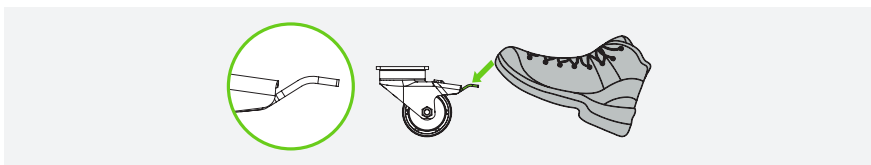

6 Electrical Connection

Notice:

Before the electrical connection, ensure that all power supplies are disconnected.

6.1 Copper Busbar Specifications

When connected in parallel, the batteries must be connected through a copper busbar. The recommended copper busbar specifications are listed below. Always comply with local laws and regulations.

Number of Batteries	Rated Current (A)	Width (mm)	Thickness (mm)
2	314	25	5
3	471	38	5
4	628	51	5
5	785	65	5
6	942	85	5
7	1099	70	10

8	1256	80	10
9	1413	90	10
10	1570	95	10
11	1727	110	10
12	1884	120	10
13	2041	125	10
14	2198	135	10
15	2355	145	10
16	2512	160	11

6.2 Single-Inverter System

6.2.1 Single-Battery System

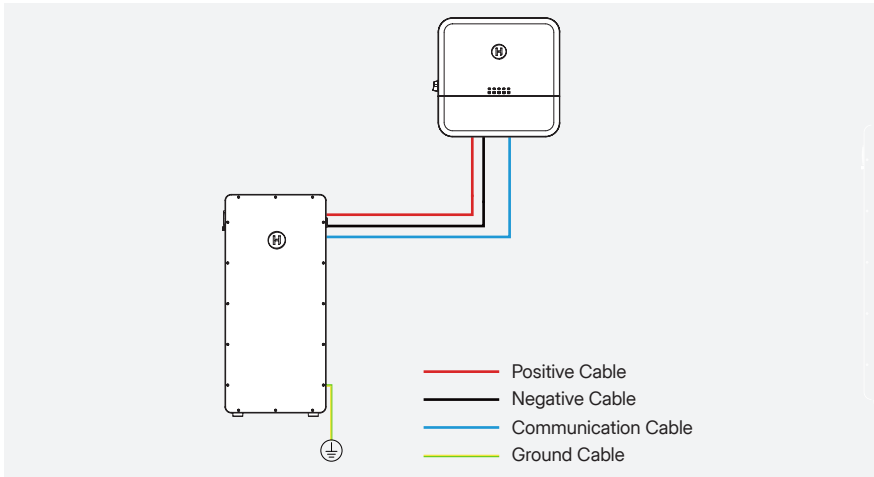

Warning:

- The maximum charging or discharging current of the battery is 157 A.
- Before wiring, check that all circuit breakers are in the OFF position.

Step 1: Use the ground cable to connect the battery to the ground.

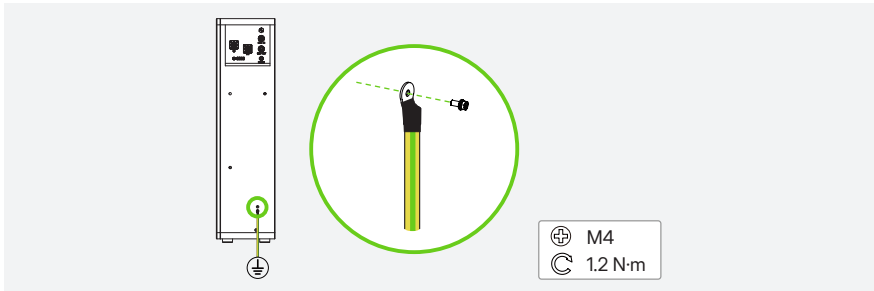

Step 2: Connect one end of the power cables respectively to the battery's positive and negative terminals, and the other end to the inverter.

Step 3: Connect one end of the communication cable to the battery's COM IN terminal, and the other end to the inverter.

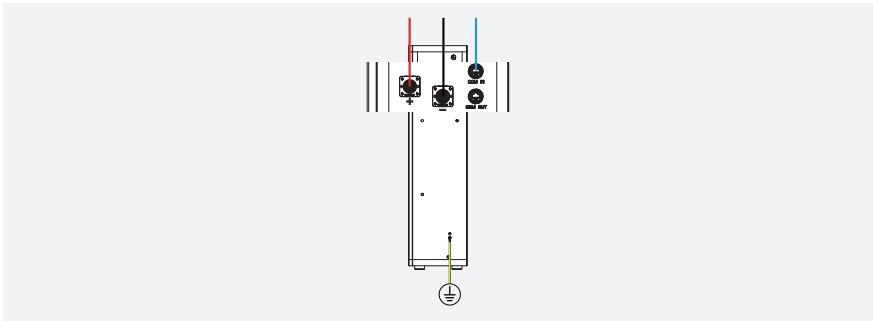

Next: Go to “7 System Commissioning” on [page 12](#).

6.2.2 Multi-Battery System

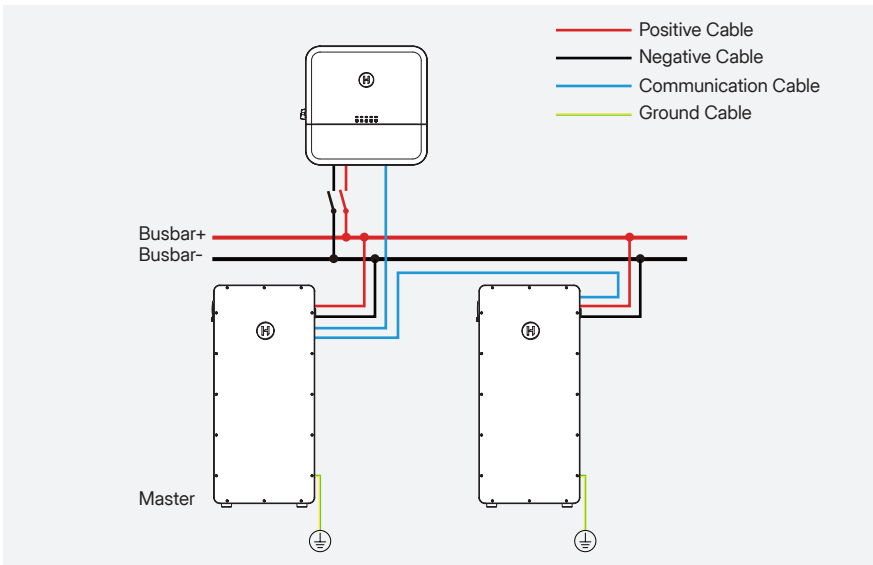

Warning:

Before wiring, check that all circuit breakers are in the OFF position.

Note:

The LB-16D-G3 series supports up to 16 batteries in parallel.

Step 1: Use the ground cable to connect the battery to the ground. For details, see the step 1 in “6.2.1 Single-Battery System” on [page 9](#).

Step 2: Connect the power cables to the busbar. For busbar specifications, see “6.1 Copper Busbar Specifications” on [page 8](#).

Step 3: Connect the communication cables.

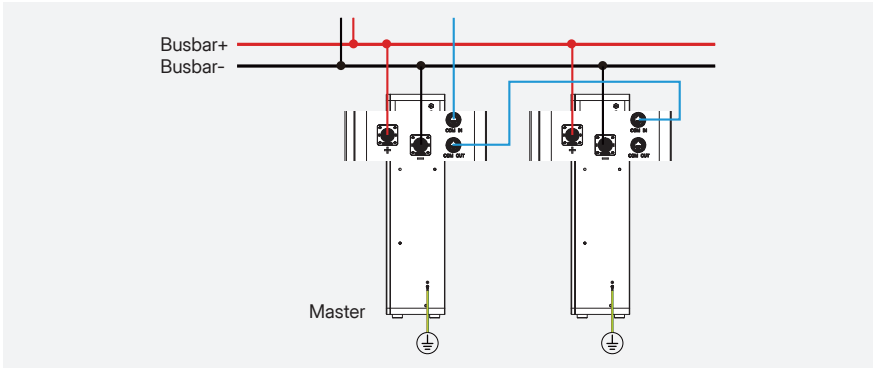

Next: Go to "7 System Commissioning" on [page 12](#).

6.3 Multi-Inverter System

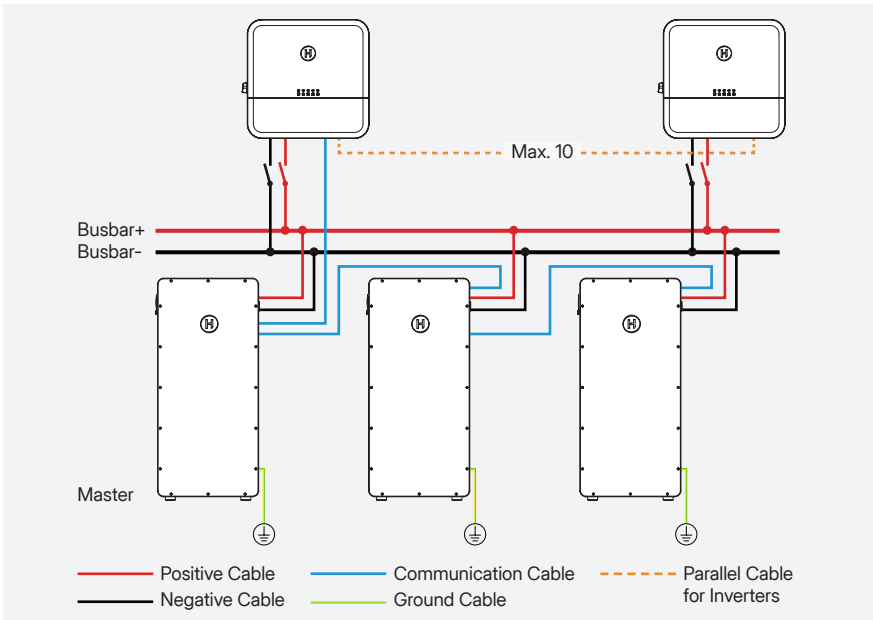

Warning:

Before wiring, check that all circuit breakers are in the OFF position.

Note:

The LB-16D-G3 series supports up to 16 batteries in parallel.

Step 1: Use the ground cable to connect the battery to the ground. For details, see the step 1 in "6.2.1 Single-Battery System" on [page 9](#).

Step 2: Connect the power cables to the busbar. For busbar specifications, see "6.1 Copper Busbar Specifications" on [page 8](#).

Step 3: Connect the communication cables.

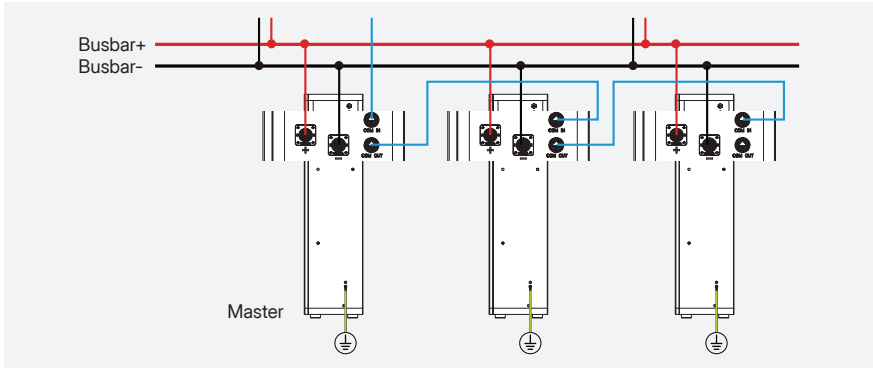

7 System Commissioning

7.1 System Power-On

Step 1: Unscrew the screws on the switch guard and open it.

Step 2: Turn on the DC circuit breaker.

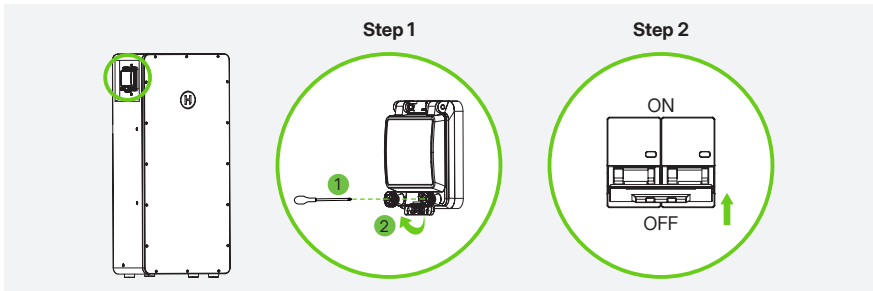

Step 3: Press the POWER button for 3 s. The status indicator will be solid blue, and the SOC indicators will flash blue (0.5 s gap), indicating the battery is in self-check state.

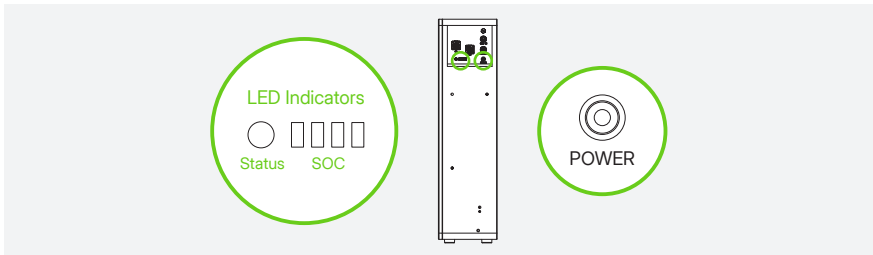

Note:

For parallel-connected batteries, if the first parallel operation fails, it may be caused by inconsistent SOC among the batteries. To solve the problem, check the voltage of each battery. If the voltage difference exceeds 0.5 V, set the battery with the lowest voltage as the Master, and enable the force charging mode to charge the battery at a maximum power of 10% until the parallel operation is successful.

7.2 LED Indicators

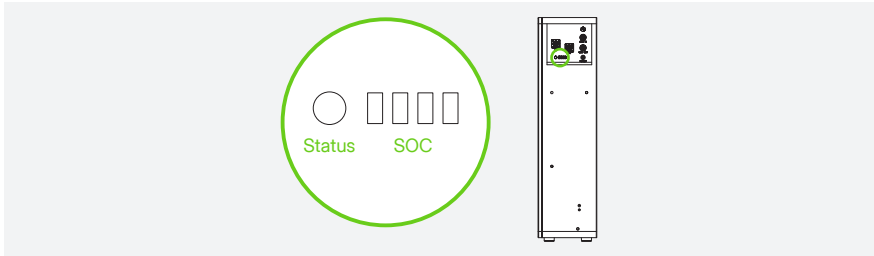

Indicator		Indicator Status	Battery Status
Status		Solid blue	<ul style="list-style-type: none"> The battery works normally. The battery is in standby.
		Solid red	A fault occurs.
SOC		1/4 LED on	SOC is 0-25%.
		2/4 LEDs on	SOC is 25%-50%.
		3/4 LEDs on	SOC is 50%-75%.
		All LEDs on	SOC is 75%-100%.
		Flashing blue in a rightward sequence	The battery is charging.
		Flashing blue in an leftward sequence	The battery is discharging.
All		Status indicator solid blue, SOC indicators flashing blue (0.5 s gap)	<ul style="list-style-type: none"> The battery is in precharge. The battery is in self-check. The battery is being upgraded.
		Status indicator solid red, SOC indicators flashing blue (0.5 s gap)	Communication failure occurs.
		Off	The battery is turned off.

7.3 (If Needed) System Power-Off

Step 1: For a single-battery system, press the POWER button for 3 s.

For a parallel system, press the POWER button on the Master battery for 3 s.

Step 2: Turn off all DC circuit breakers.



Scan the QR code or visit our website
www.hoymiles.com/download-center.html
to access the manual.



Scan the QR code or visit our YouTube
www.youtube.com/@Hoymiles/videos
to access the installation video.



Hoymiles Power Electronics Inc.

Add: Floor 6, Building 5, 99 Housheng Road,
Gongshu District, Hangzhou 310015, P. R. China

www.hoymiles.com

Tel: +86 571 2805 6101

Email: service@hoymiles.com
support@hoymiles.com



A400300481