

Data Transfer Unit USER MANUAL

DTU-WLite-S

Legal Notice

Hoymiles has made every effort to ensure the accuracy and completeness of this manual. However, this manual may be changed and revised due to product enhancements or user feedback.

Hoymiles reserves the right to modify this manual without prior notice at any given time. The latest version of this manual can be found by visiting the Hoymiles official website (www.hoymiles.com) or scanning the QR code below.



Contact Us

If you have technical queries or any questions concerning our products, please contact our support through the Hoymiles service portal:

**Germany**

service.de@hoymiles.com

Italy

service.it@hoymiles.com

Poland

service.pl@hoymiles.com

Other EU countries

service.eu@hoymiles.com

Brazil

service.br@hoymiles.com

Asia & Pacific

service.asia@hoymiles.com

Spain

service.es@hoymiles.com

Netherlands

service.nl@hoymiles.com

Finland

service.fi@hoymiles.com

USA

service.us@hoymiles.com

Spanish-speaking LA countries

service.mx@hoymiles.com

France

service.fr@hoymiles.com

Norway

service.no@hoymiles.com

Austria

service.at@hoymiles.com

Canada

service.ca@hoymiles.com

Australia & New Zealand

service.au@hoymiles.com

**Germany**

+49 6994322186

Poland

+48 918821656

France

+33 159131589

USA & Canada

+1(205)395-5515

Netherlands

+31 852736388

Brazil

+55 1148585231



hoymiles.com

Revision History

Version	Description
REV1.2	<ul style="list-style-type: none">Added 1.4 Regulatory Compliance StatementUpdated 2 Hoymiles Microinverter SystemUpdated 4 InstallationUpdated operation instructions of S-Miles Cloud and related screenshotsUpdated 7 Technical Data
REV1.1	This issue marks the initial official release.

CONTENTS

1	Important Safety Information	02
1.1	Read This First	02
1.2	Audience	02
1.3	Safety Instructions	02
1.4	Regulatory Compliance Statement	02
2	Hoymiles Microinverter System	03
3	Product Information	04
3.1	Interface Layout	04
3.2	Dimensions	04
3.3	LED Indicators	04
4	Installation	05
4.1	Preparation	05
4.2	Installation Steps	06
4.3	On-site Commissioning (Optional)	08
5	Setting Up Monitoring	10
6	DTU Replacement	12
7	Technical Data	13

1 Important Safety Information



1.1 Read This First

This manual includes instructions for installing and maintaining the Hoymiles Data Transfer Unit DTU-WLite-S. DTU-WLite-S is compatible with Hoymiles HMS series, HMT series, and MiS series microinverters.

1.2 Audience

This manual is intended for use by professional installation and maintenance personnel only.

1.3 Safety Instructions

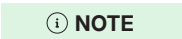
Symbol	Description
 DANGER	This symbol indicates potential risks that, if not avoided, may lead to death or serious physical injury.
 CAUTION	This symbol indicates potential risks that, if not avoided, may lead to device malfunctions or financial losses.
 NOTE	This symbol indicates an important step or tip that leads to the best results but is not safety or damage-related.

DANGER

Do not use Hoymiles products in a way that is not suggested by the manufacturer. Otherwise, it can cause death, personal injuries, or equipment damage.

CAUTION

- Only qualified personnel can install or replace the DTU. Hoymiles is not liable for damages resulting from improper installation and use.
- Install the DTU away from dust, liquid, and corrosive gases.
- Do not attempt to repair the DTU. Contact your installer or distributor for maintenance. Unauthorized disassembly of the DTU is strictly forbidden, and voids the warranty.
- Read all instructions and warnings in the technical specifications carefully.

1.4 Regulatory Compliance Statement

Hoymiles confirms that the product described in this guide meets the essential requirements and relevant provisions of the EU directives.

Radio Technology	Frequency Bands	Maximum Output Power
Wi-Fi	2412 to 2472 MHz	20 dBm
Sub-1G	863.25 to 869.75 MHz	14 dBm

These technical parameters apply only to EU countries.

EU Directive Compliance

This product complies with the following EU directives and can be used without restrictions in the European Union:

- Directive 2014/53/EU (RED) and 2009/125/EC: Relating to the provision of electrical equipment within certain voltage limits on the market (Low Voltage Directive).
- Directive 2011/65/EU and 2015/863/EU (RoHS): Restricting the use of certain hazardous substances in electrical and electronic equipment.

The full text of the EU Declaration of Conformity (DoC) is available at: www.hoymiles.com.



2 Hoymiles Microinverter System

A typical Hoymiles microinverter system is composed of Hoymiles microinverters, the DTU, and Hoymiles monitoring platform S-Miles Cloud.

Microinverters

Microinverters are small inverters installed directly beneath PV modules or nearby. They convert DC electricity from the PV modules into AC electricity, which can power the connected loads or be fed back into the grid.

Microinverters use a sophisticated MPPT algorithm to optimize the performance of each PV module. This ensures that the overall performance of PV modules in the row will not be dragged down if one PV module underperforms.

DTU

The DTU is a key component in the Hoymiles microinverter system. It works as the communication gateway between Hoymiles microinverters and S-Miles Cloud. It communicates with the microinverters in a wireless way, and collects the operation data of the system. Meanwhile, it communicates with S-Miles Cloud via Wi-Fi, uploading the system operation data for remote monitoring and O&M.

S-Miles Cloud

S-Miles Cloud is a comprehensive monitoring and analysis platform. It monitors the microinverter system from afar, providing real-time insights into the whole system's performance and enabling you to keep track of your microinverter system's status. It also enables module-level monitoring and remote management.

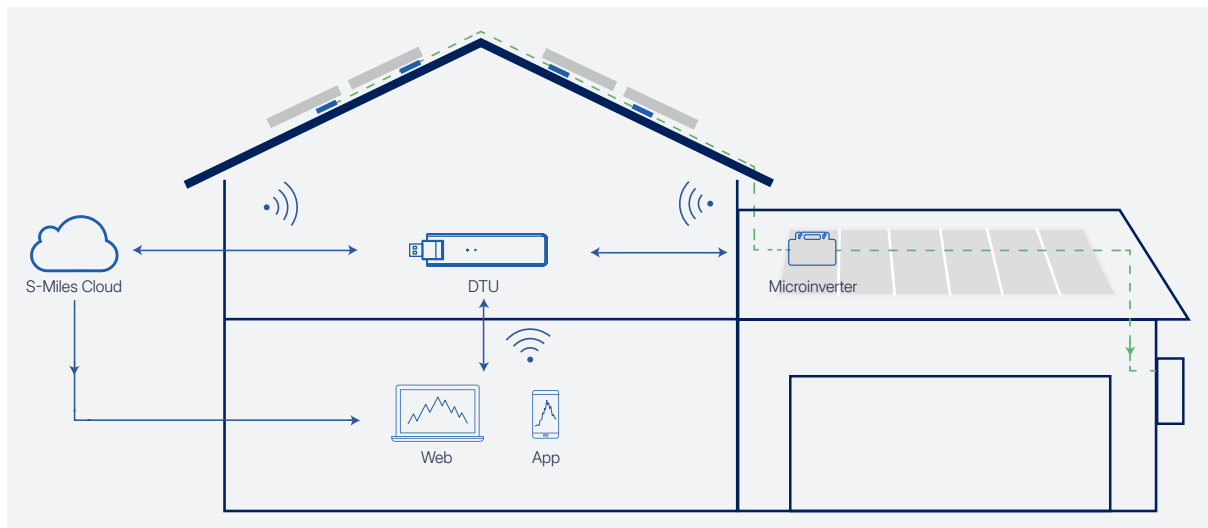

3 Product Information

3.1 Interface Layout

Item	Description
A	USB Connector
B	Status Indicator
C	Reset Button

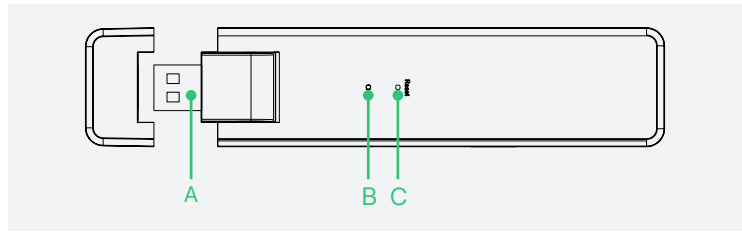

3.2 Dimensions

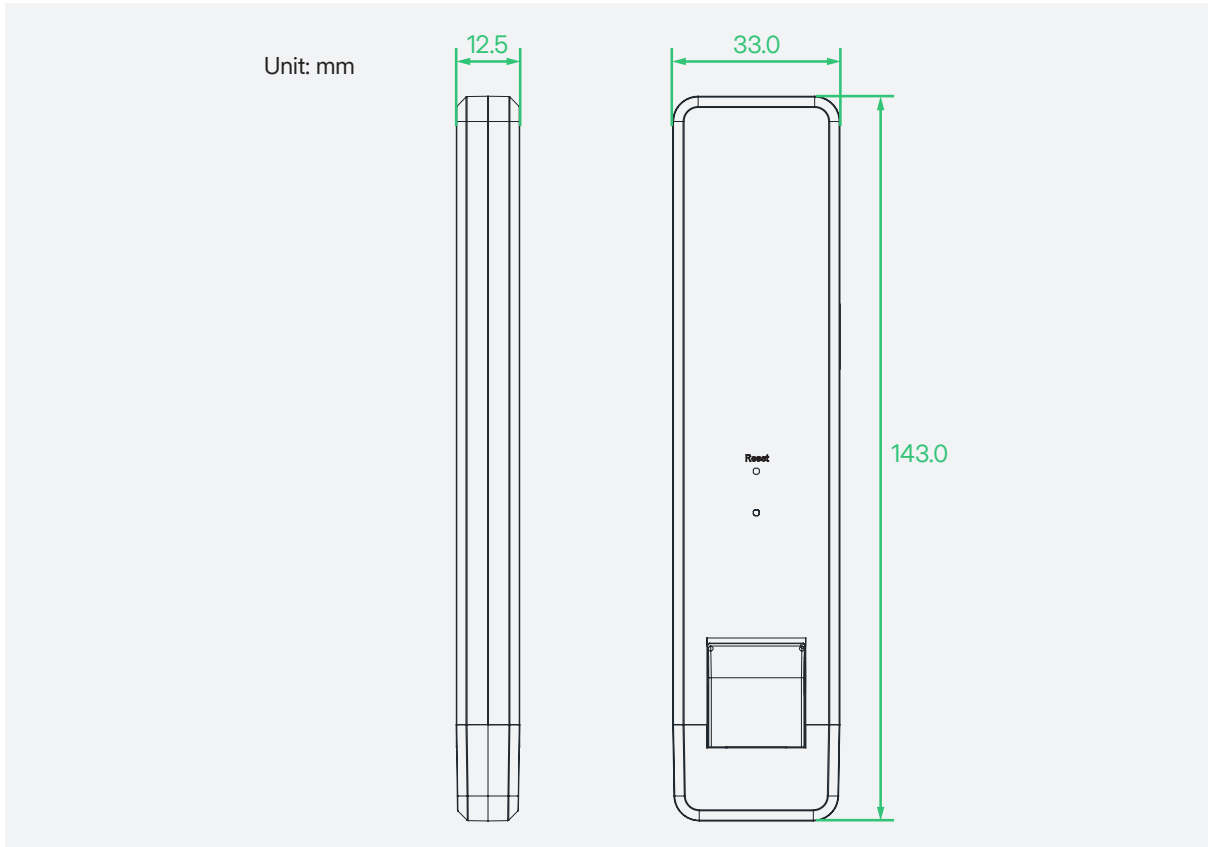

3.3 LED Indicators

You can learn about the system status via LED indicators.

Indicator	Indication
	Wi-Fi disconnected
	Connection with server failed
	No microinverters during DTU networking
	Data received from the server
	ID searching incomplete
	Normal
	Power on
	Firmware upgrading

4 Installation

4.1 Preparation

Package Contents

Check the package for the following items:

- DTU-WLite-S
- Adapter
- Installation Map

System Capacity

The DTU-WLite-S is capable of monitoring up to 4* PV modules. However, the number may be reduced if the communication between the DTU and the microinverters is affected by installation conditions.

Note: The maximum number of PV modules depends on the following factor:

- **Installation method:** The DTU and microinverters must be installed in open space, following the conditions specified in their respective manuals. Also, the required distance between the DTU and microinverters must be maintained.

Installation Location

Decide the installation location following the requirements.

- Install the DTU away from dust, liquid, and corrosive gases.
- The ambient temperature should be between -20 °C and 55 °C.
- Install the DTU on the top floor to increase signal strength.
- Install the DTU near the center of the PV array.
- Install the DTU at least 0.5 m above the ground, and try to install the DTU at a 90 degrees angle perpendicular to the ground.
- Do not install the DTU directly above metal or concrete, as this may cause signal interference.

Monitoring Application

Scan the QR code below to download Hoymiles S-Miles Installer application.



Installation Procedure

The chart below illustrates a typical installation procedure of Hoymiles microinverter system. You need to complete these steps on site except the last two.

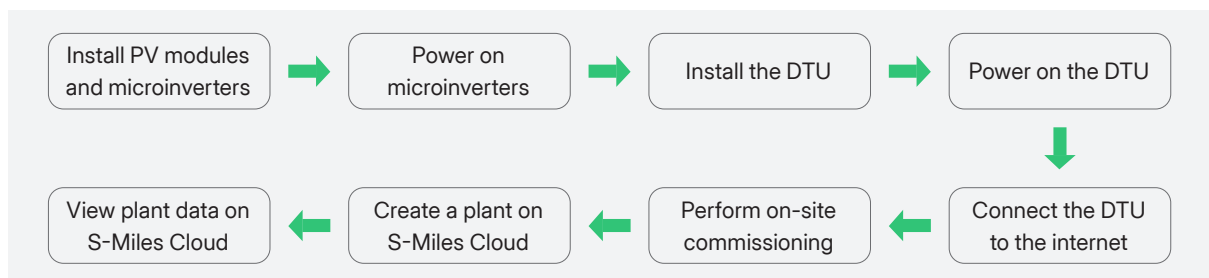

4.2 Installation Steps

Step 1 Power the DTU

Option 1: Connect the DTU to the adapter and plug it into the wall socket.

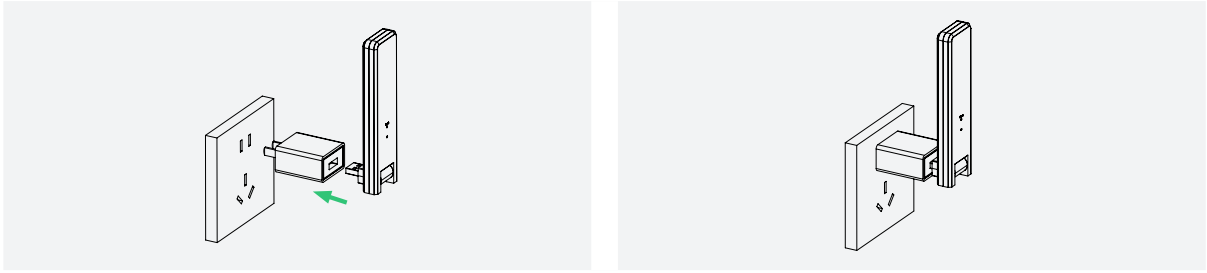

Option 2: Connect the DTU to the adapter and plug it into the power strip.

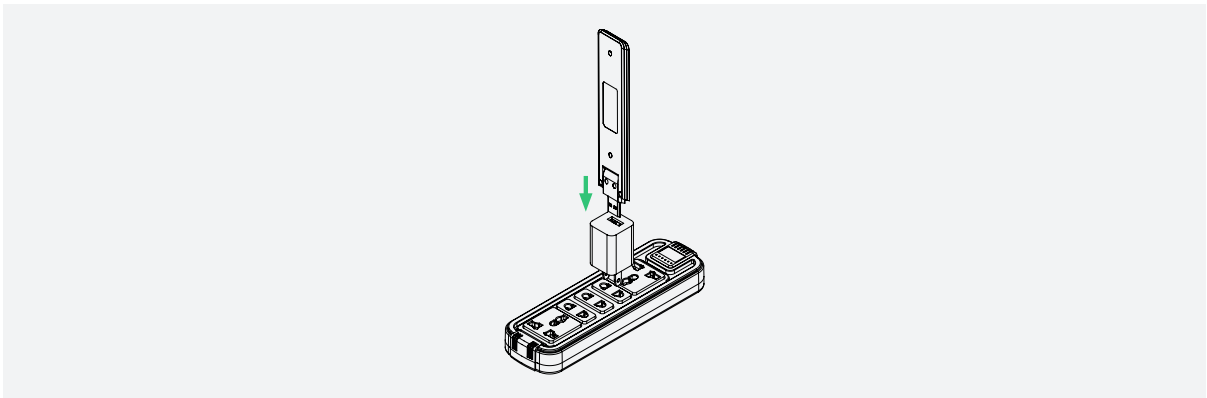

Step 2 Check the indicator

Once the DTU powers on, the red, green, and blue lights will flash for one second in turn for 30 seconds.

Step 3 Establish an internet connection

NOTE

- The screenshots provided in this manual are for reference only. The actual screens may vary.
- The DTU's network name is DTUL-last 8 digits of the SN, and is password-free by default.

A) Open and log in to S-Miles Installer using your credentials.

B) Tap **O&M** > **Network Config**.

C) Tap the picture of the DTU, and then tap **Go to set**.

D) Select the DTU's network.

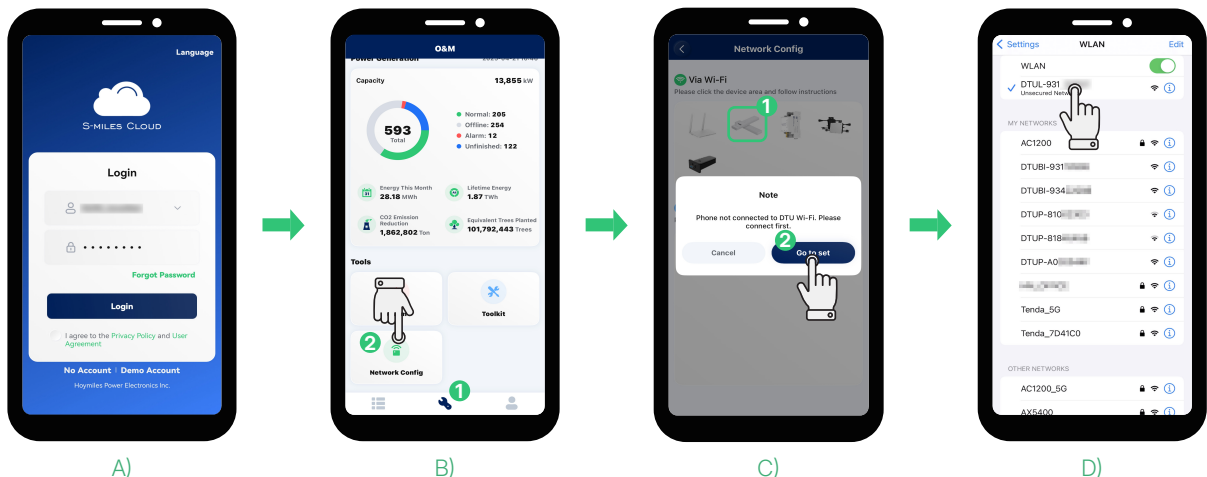

- E) Return to the App, and set the new DTU AP password.
- F) Wait for about 30s, and connect to the DTU’s network again using the new password.

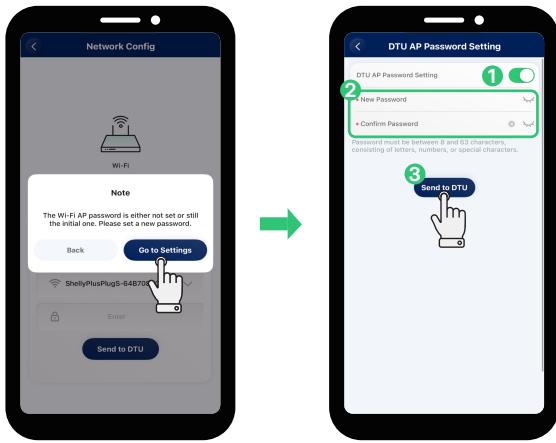

E)-1

E)-2

- G) Return to the App, and tap **Network Config** .
- H) Select or enter the router’s Wi-Fi name, and enter the password.
- I) When the connection succeeds, tap **Finish**.

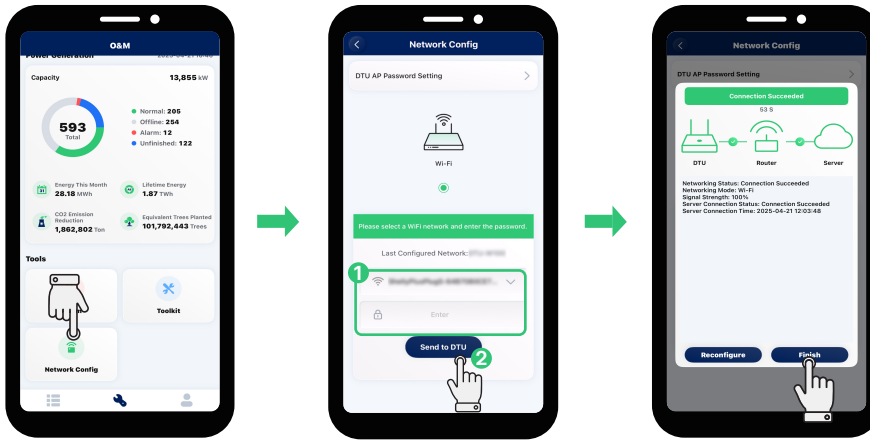

G)

H)

I)

4.3 On-site Commissioning (Optional)

We recommend you check the DTU communication quality on site using Toolkit in the S-Miles Installer App.

Step 1 Add the microinverters

NOTE

The microinverters added here are for on-site commissioning only, and the data will not be uploaded to the server. The power plant will not replace the one created on S-Miles Cloud.

A) Tap **Toolkit**  > **Power Generation and Control** > **Add Device**.

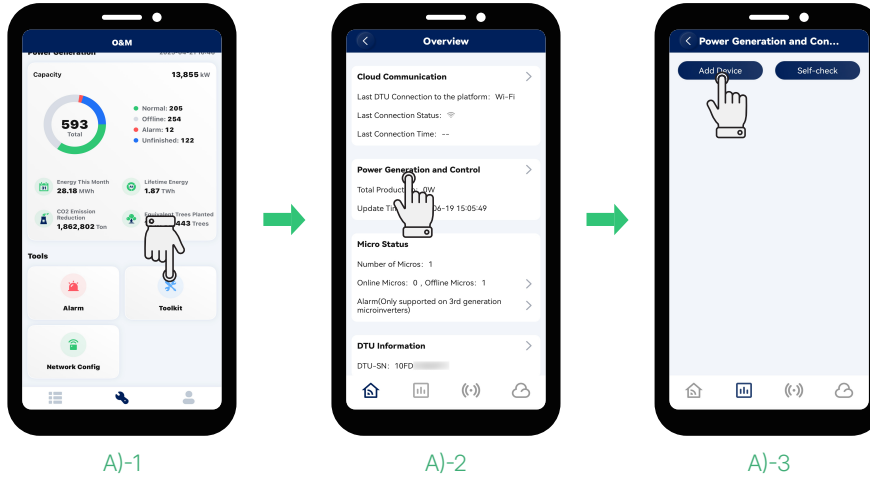

B) Add the microinverter SNs.

C) Check that all the added microinverter SNs are correct. Tap  if you want to remove a microinverter. Then tap **Save > Confirm**.

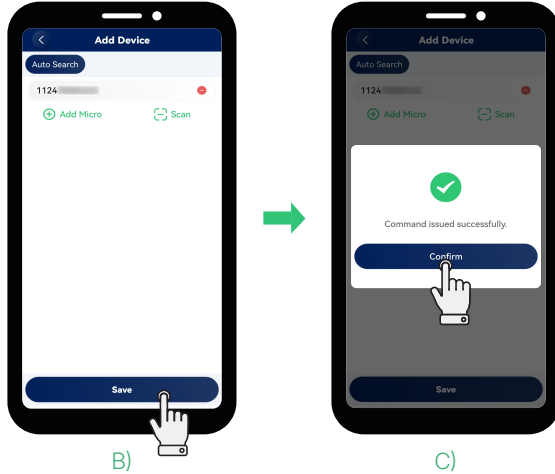

Step 2 View the microinverter data and the connection status

- A) Tap **Power Generation and Control**.
- B) Tap the SN of the target microinverter. The real-time data is shown on the screen.
- C) Tap **Connection Status**. The real-time connection status is shown on the screen.

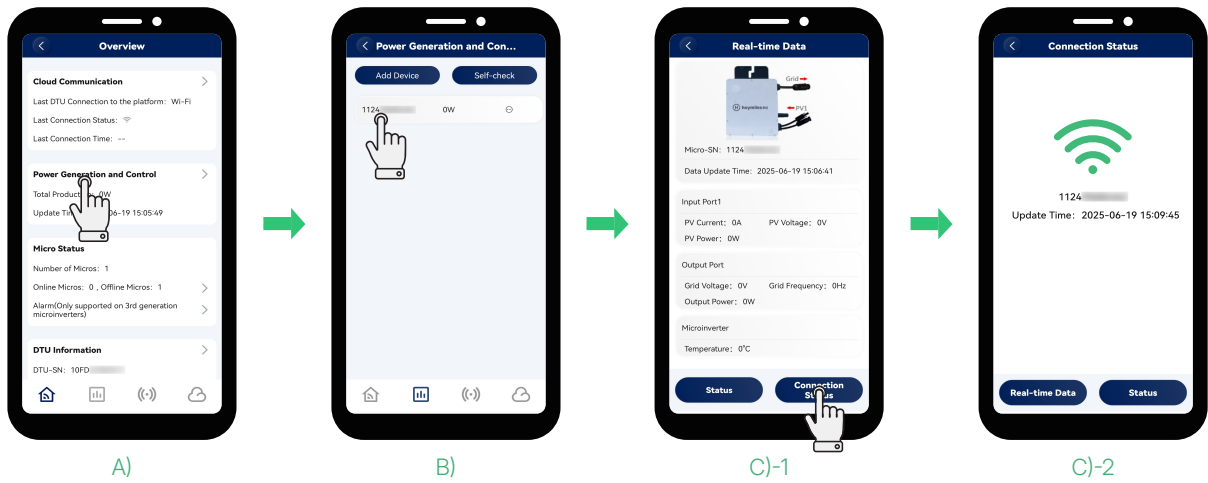
**NOTE**

If there is no signal, ensure the microinverters are powered on, or refer to the microinverter user manual for troubleshooting.

5 Setting Up Monitoring

Follow the procedure below to set up monitoring.

Step 1 Create your power plant

- A) Tap **Plants** > .
- B) Fill in the plant and owner information according to the prompts.



A)

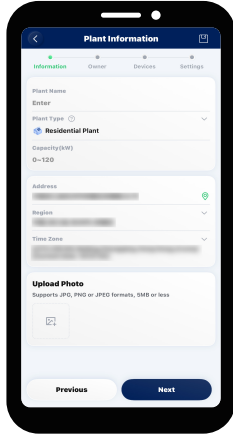

B)-1

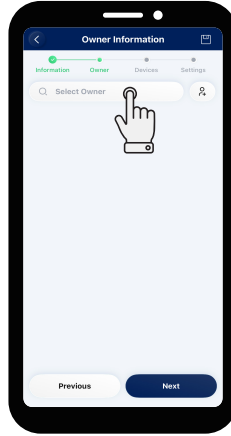

B)-2

- C) On **Bind Devices**, tap and enter or scan the DTU SN.
- D) Tap **Add Micro**, and enter or scan the microinverter SN. Tap **Finish** after adding all devices.

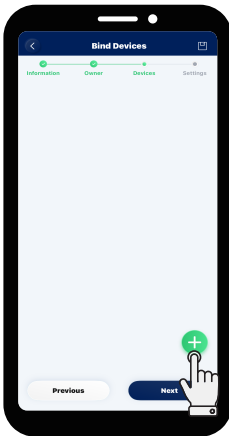

C)-1

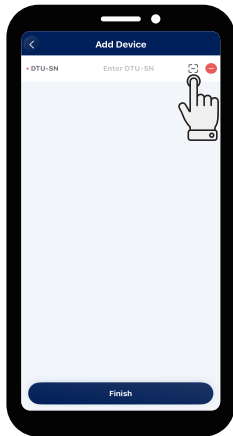

C)-2

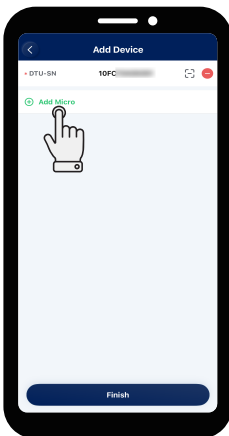
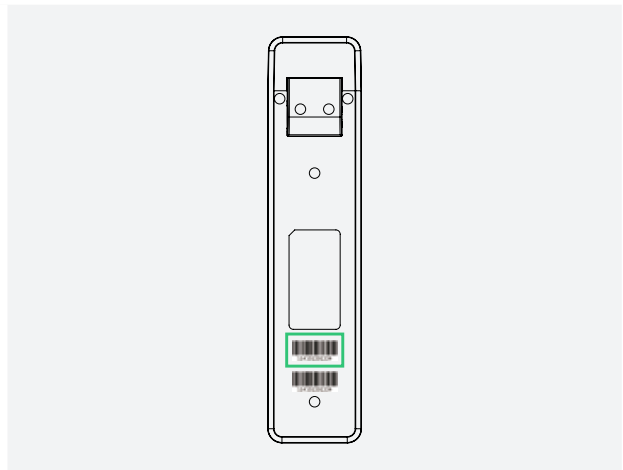

D)-1

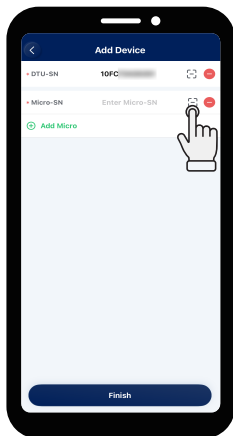

D)-2

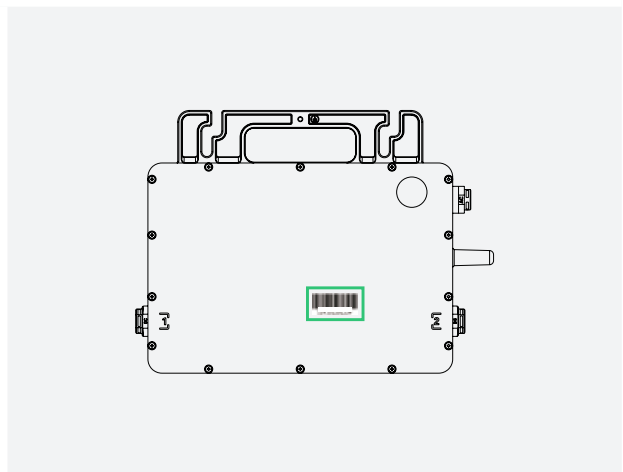

E) Follow the prompts to complete other plant settings.

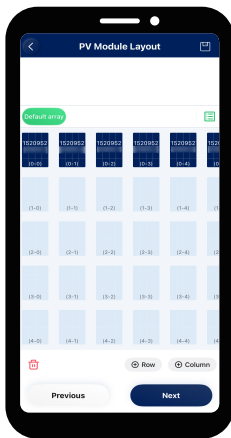

E)-1

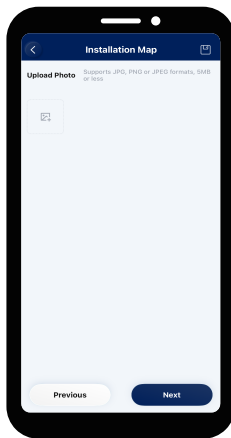

E)-2

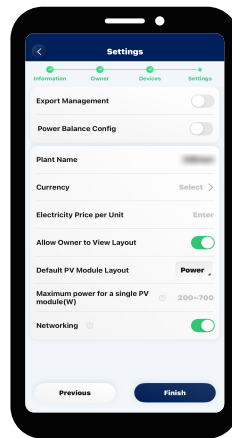

E)-3

Step 2 View the plant data

Tap the plant name in the list to move to the plant homepage.



NOTE

- For more details on plant data viewing, consult [S-Miles Cloud \(App\) User Manual](#).
- You can also set up monitoring on S-Miles Cloud Web. Consult [S-Miles Cloud \(Web\) User Manual](#) for instructions.

6 DTU Replacement

Follow the procedure below to replace the DTU.

Step 1 Replace the DTU on site

- A) Remove the original DTU.
- B) Record the new DTU's SN.
- C) Install the DTU following instructions in [4.2 Installation Steps](#).

Step 2 Replace the DTU on S-Miles Cloud

- A) Log in to S-Miles Cloud at www.global.hoymiles.com.
- B) Click **O&M > Device List**.
- C) Select the plant which the DTU belongs to in the filter, or enter the device SN, and click **Search**.
- D) Click .

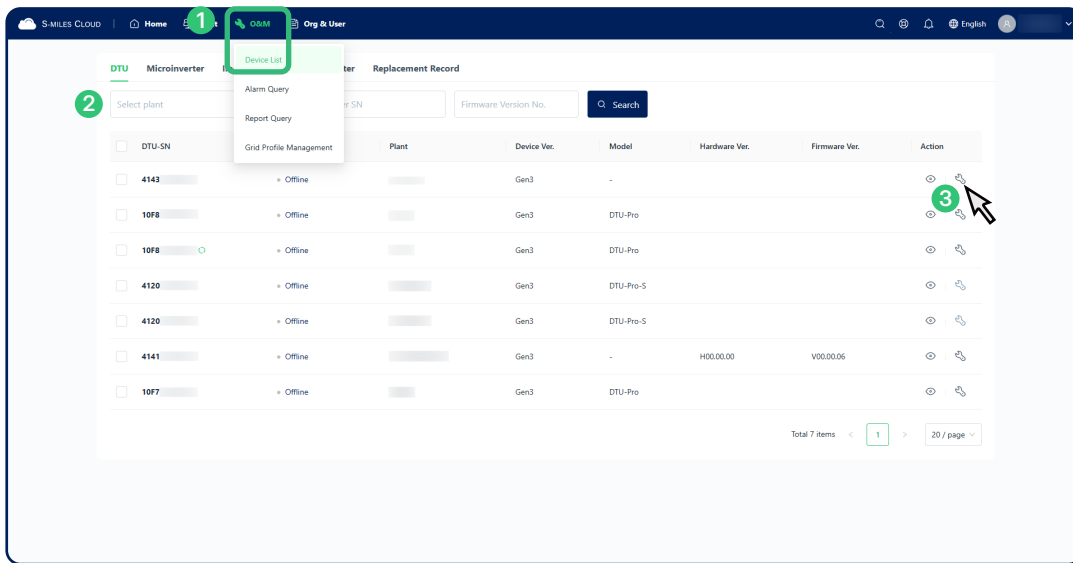

- E) Click **Replace Device**.
- F) Enter the SN of the new DTU, and click **Confirm**.

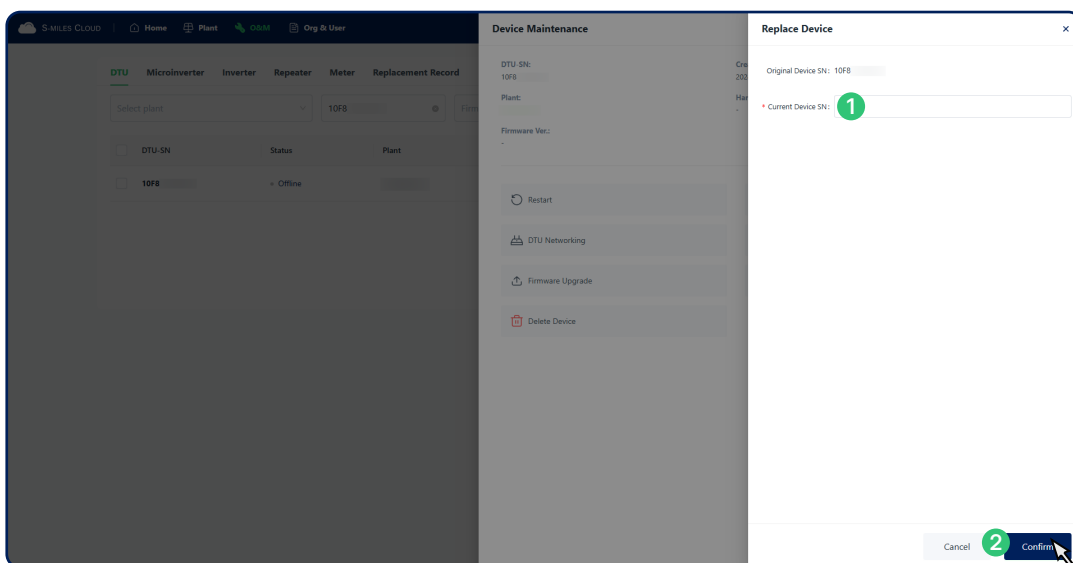

7 Technical Data

Model	DTU-WLite-S
Communication to Microinverter	
Type	Sub-1G
Maximum distance (open space) (m)	400
Monitoring data limit from solar panels ¹	4
Communication to S-Miles Cloud	
Wireless standard	802.11 b/g/n
Radio band (GHz)	2.4
Sample rate (min)	Per 15
Interaction	
LED	LED Indicator
Local App	S-Miles Installer
Power Supply (Adapter)	
Type	External adapter
Adapter input voltage/frequency	100 to 240 V AC / 50 or 60 Hz
Adapter output voltage/current	5 V / 2 A
Power consumption (DTU) (W)	Typ. 1.0 / Max. 5.0
Mechanical Data	
Ambient temperature (°C)	-20 to +55
Dimensions (W × H × D [mm])	143 × 33 × 12.5
Weight (g)	43
Installation option	Direct plug-in
Compliance	
Certificate	CE
Microinverter Compatibility	
Microinverter model	HMS series, HMT series, MIS Series

^{*1} This depends on the installation environment. Please refer to [4 Installation](#) for more details.